

# INTEΨA



## **AQUALOOP - direct ultrafiltration unit**

Assembly and operating instructions

Code: AL-direct

Item no.: 230196

WASSER IST UNSER ELEMENT

## Table of contents

1	Introduction.....	2
2	Safety instructions.....	3
3	Scope of delivery .....	4
4	Functional description .....	5
5	Technical data .....	6
6	Operating variants.....	8
6.1	Operation with geodetic pressure .....	8
6.2	Operation with pump pressure .....	9
6.2.1	Operation in parallel connection .....	10
7	Installation and commissioning .....	11
8	Maintenance and storage .....	13
8.1	Mechanical cleaning.....	13
8.2	Dry cleaning.....	15
8.3	Storage .....	17
9	Spare parts and cleaning agents .....	17
10	Warranty .....	18
11	Contact.....	18
	Appendix.....	19
	Appendix 1.1 LOG reduction.....	19
	Appendix 1.2: Declaration of conformity of the membrane .....	20

## 1 Introduction

AQUALOOP direct (AL-direct) is a direct filtration unit with an ultrafiltration membrane. The membrane technology retains even the smallest particles in the water, such as microorganisms, bacteria and viruses larger than 0.02 µm. AL-direct can be operated either with geodetic pressure or with the aid of a pressure pump.

### The following waters, among others, can be filtered:

- Rainwater
- River water
- Spring water
- Tap water
- Discharge water from small wastewater treatment plants

### Possible areas of application:

- Drinking water from roof run-off water (rainwater)
- Hygienised water for adiabatic cooling
- Process water for industry and commerce
- as a filter pre-stage for RO systems
- Hygienised irrigation water

### Possible areas of application:

- Households, schools, housing
- Industry and trade
- Campsites, disaster control

### Advantages:

- Small space requirement, direct filtration (no clear water buffer tank required, therefore no post-contamination)
- Very large membrane surface area of 18 m<sup>2</sup>, therefore long service life and high flow rate, modularly expandable
- Simple installation, commissioning and operation
- Removal (membrane barrier) of particles, bacteria, viruses, worm eggs
- Robust, mechanical filter process, chemical cleaning if required

## 2 Safety instructions



Before installing the product, you must read these installation and operating instructions carefully. The instructions contained therein must be observed. Modifications to the product are not permitted as this will invalidate any warranty.



Dissolved, organic or inorganic substances (chemicals) in raw water are not removed by ultrafiltration. If the water is intended for human consumption, it must be ensured that these substances do not exceed the limit values of the Drinking Water Ordinance. **For drinking water applications, the treated water must therefore be analysed before use.**



If the product is not used regularly, it must be cleaned or disinfected before use (see chapter Storage). Contamination on the treated water side must also be avoided.

The customer is responsible for regular quality and safety checks. If the filtration results deteriorate (e.g. increase in turbidity), the system must be stopped, cleaned and checked immediately.

The operator is responsible for compliance with the safety and installation regulations.

The following points must be observed for installation and operation:

- Check the product for visible defects before installation. If there are any defects, the product must not be installed.
- All products must be checked regularly to ensure that they are in good condition.

### 3 Scope of delivery

1. 15-litre filter housing incl. UF membrane bundle
2. Connection unit for input side with:
  - Pipe section incl. seal / clamping ring and T-piece with 2/3 union fitting
  - Ball valve 3/4" ready for connection with 1/3 screw connection
  - Ball valve 3/4" ready for connection with 1/3 screw connection
3. Connection unit for output side with:
  - Pipe section bent 90° with seal/clamping ring, ball valve 3/4" ready for connection with 1/3 screw connection
  - 2/3 Screw connection loose
4. Venting connection fitting:
  - Ball valve 1/4" loose

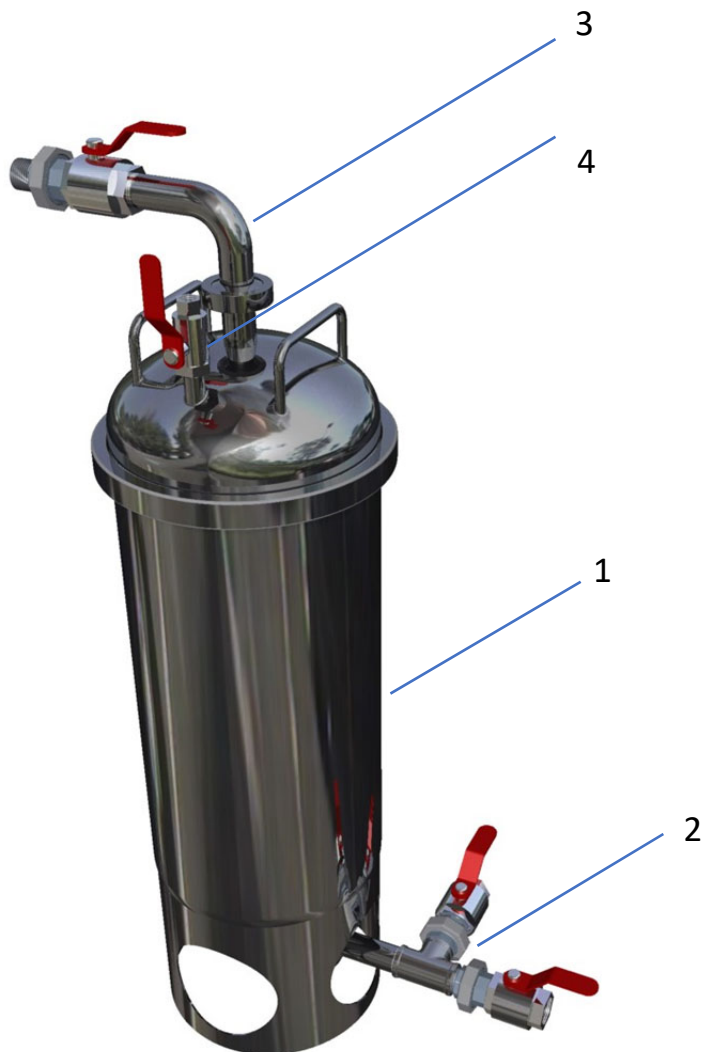

## 4 Functional description

AL-direct is an ultrafiltration unit based on the outside-in filter principle. The raw water is fed into the filtration housing (2) via the inlet nozzle (1) and pressed through the UF fibre bundles (3) by the upstream pressure of the inlet water. Particles and bacteria/viruses are safely retained on the outside of the membrane fibres. The clear water inside each membrane fibre is brought together via the respective central pipe (4) and the clear water from all three central pipes is fed to the outlet nozzle (5) via the distributor (5).

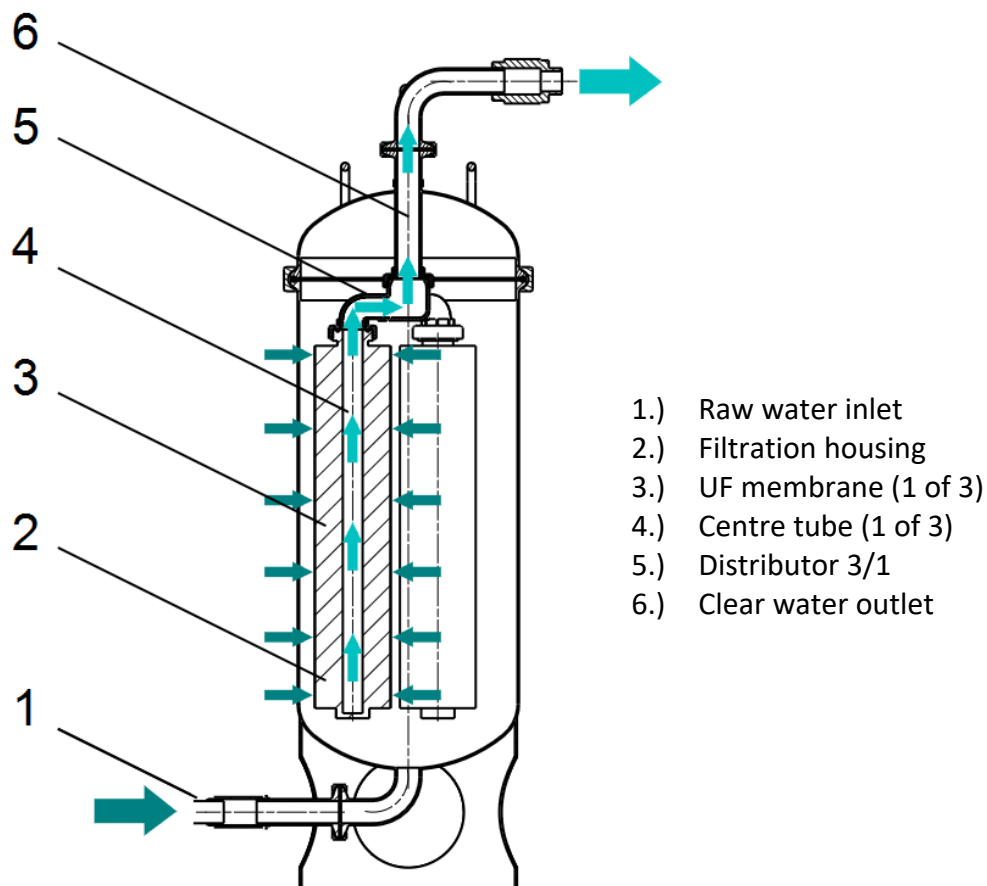

Fig.: Filtration principle, illustrated on a UF membrane

## 5 Technical data

<b>Article:</b>	<b>AL-direct</b>
<b>Filter housing:</b>	
Height	810 mm
Diameter	219 mm
Inlet connection	¾" IG
Drain connection	¾" IG
Dirt drain	¾" IG
Vent connection	¼" IG
Material	Stainless steel SS304
Max. operating pressure	6 bar
Weight	12 kg

### Ultrafiltration membrane:

Number of membrane bundles:	3 pieces
Filter area of a membrane bundle:	6 m <sup>2</sup>
Membrane fibre material / type:	PE / hollow fibre
Medium pore size:	0.02 µm
Antifouling:	Yes
Pre-moistening:	Yes
Max. filtration capacity:	60 l/min at 3.5 bar differential pressure
Temperature range:	0 - 40 °C
Max. Transmembrane pressure:	3 bar
Max. backwash pressure:	0.5 bar
Max. free chlorine at 25°C or lower:	5000 ppm at 9.5 pH during chem. cleaning
Max. cleaning performance (free chlorine):	1.0 million ppmh (cumulative hours)
Membrane bundle:	PE
O-ring seal of the centre pipes:	Ø 26mm x 3.5 mm
Lifetime:	Max. 10 years
Bacteriological test certificate:	Laboratory HUS Salzburg
Hygiene Declaration of Conformity *:	Yes
Test standard:	EN ISO 9308-1 STANDARD
Retention of viruses / bacteria up to:	Log 4/Log7**

*\*A declaration of conformity for the ultrafiltration membrane PE 1700/400 can be found in Appendix 1.2*

*\*\*A measurement example of a load test performed showing the log reduction value of AL diaphragms can be found in Appendix 1.1*

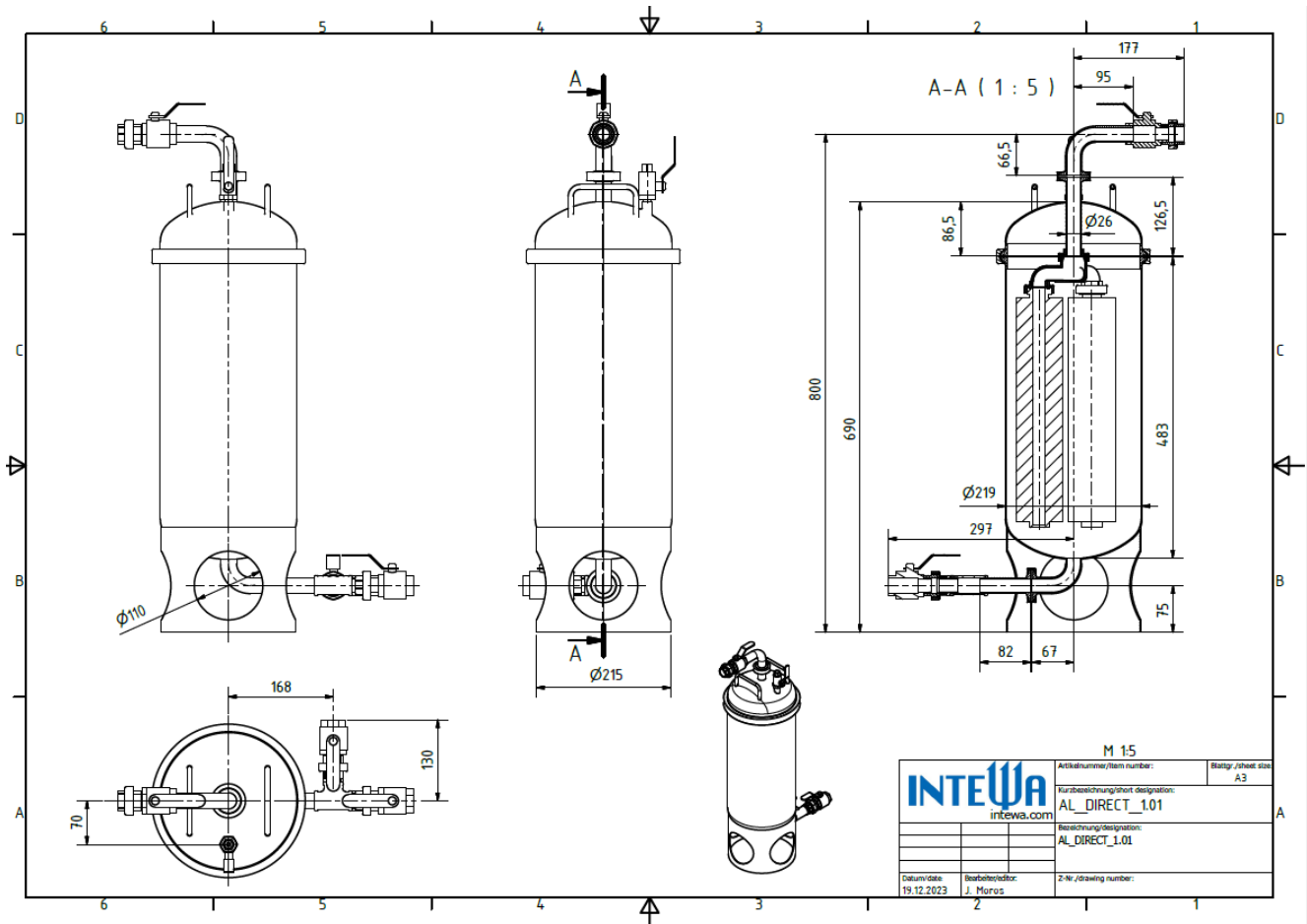

Fig.: Overview with dimensions



## 6 Operating variants

### 6.1 Operation with geodetic pressure

AL-direct can be operated with geodetic pressure. The following table shows an example of the flow rate as a function of the feed height.

*Table: Exemplary flow rate of pre-cleaned rainwater depending on the height  $\Delta H$*

Height $\Delta H$	Flow rate (max. = new condition)	Flow rate (in operation*)
0.5 m ( 50 mbar)	2.1 L/min $\cong$ 3,000 L/day	0.6 L/min $\cong$ 864 L/day
1.0 m (100 mbar)	6.0 L/min $\cong$ 8,640 L/day	1.8 L/min $\cong$ 2,592 L/day
2.0 m (200 mbar)	9.6 L/min $\cong$ 13,824 L/day	3.0 L/min $\cong$ 4,420 L/day
3.0 m (300 mbar)	13.2 L/min $\cong$ 19,008 L/day	3.6 L/min $\cong$ 4,800 L/day

\* The flow rate is strongly dependent on the raw water quality and the particulate clogging condition of the membranes

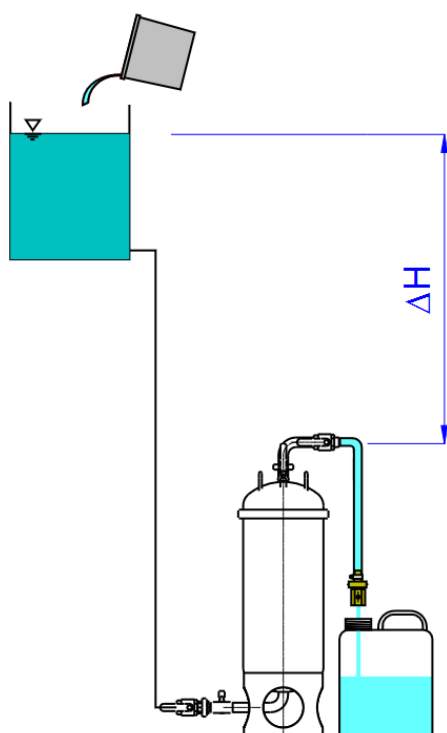

*Image: AL-direct with geodetic filtration*

## 6.2 Operation with pump pressure

The inlet pressure into the diaphragm housing must not exceed 6 bar.

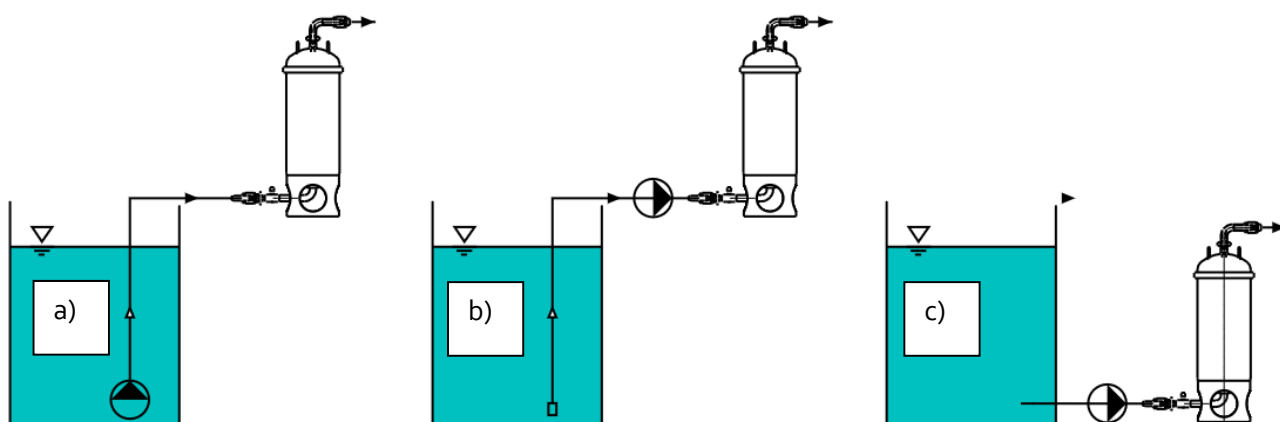

Image: AL-direct with a.) submersible motor pump, b.) pressure pump in suction mode, c.) pressure pump with water supply

Depending on the degree of soiling of the water, the flow rate is reduced over time until cleaning is required.

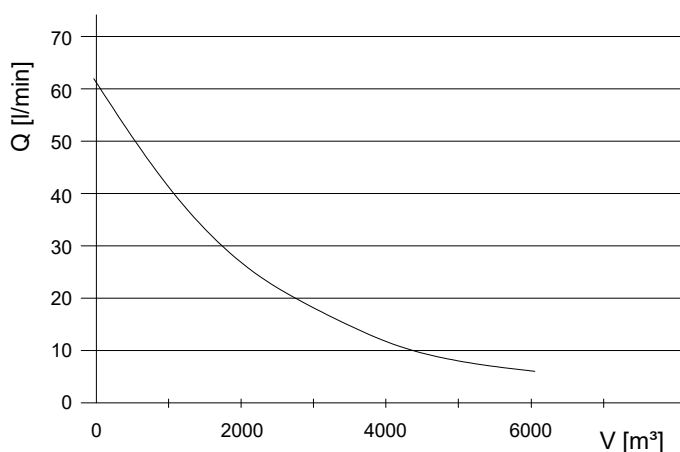

Figure: Example flow curve with pre-cleaned roof run-off water (rainwater) and cleaning every 50 m<sup>3</sup> of pumped volume

Table: Exemplary, possible flow rate and influence of the daily flow rate on the maintenance interval for pre-cleaned roof run-off water (rainwater)

Pump pressure	Flow rate max. [l/min] / [m <sup>3</sup> /h] (= new condition)	Flow rate up to maintenance [l/min] (in operation)*	Daily throughput [l/day]	Maintenance interval
3.5 bar	60 / 3,6	60 - 12	500 litres/day	4 years
3.5 bar	60 / 3,6	60 - 12	1000 litres/day	2 years
3.5 bar	60 / 3,6	60 - 12	1500 litres/day	1 year

\*Note: The flow rates are approximate as they are highly dependent on the raw water quality and the clogging condition of the membrane.

## 6.2.1 Operation in parallel connection

The filtration performance can be increased by parallel connection.

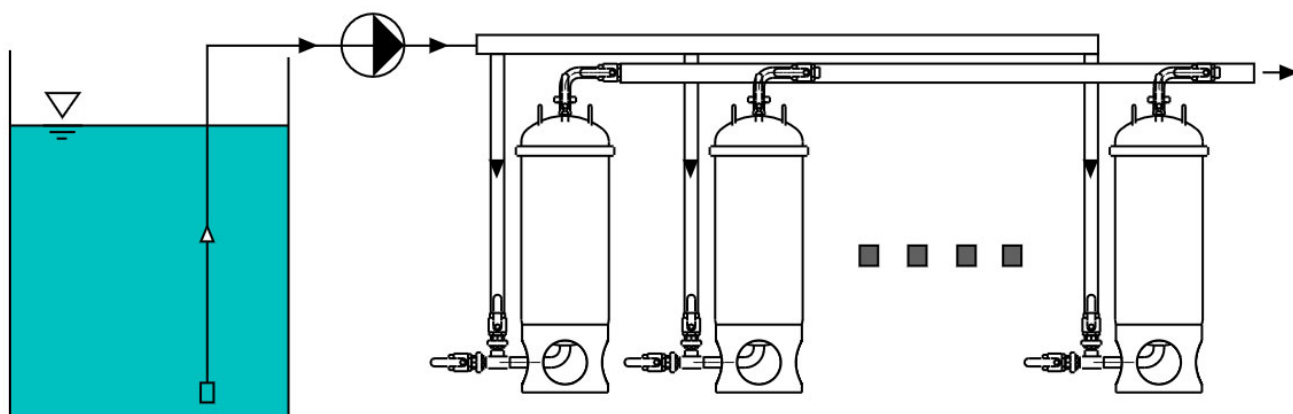

Image: AL-direct in parallel operation

The following table shows examples of versions with one, two and four AL-direct filter units in parallel operation:

Table: Example of possible flow rate and daily flow rate with pre-cleaned roof run-off water (rainwater) at a maintenance interval of 1 year

	Pump pressure	Flow rate max. [l/min] / [m <sup>3</sup> /h] (= new condition)	Flow rate up to maintenance [l/min] (in operation)	Daily throughput [l/day]
1 x AL-direct	3.5 bar	60 / 3,6	60 - 12	1500 litres/day
2 x AL-direct	3.5 bar	120 / 7,2	120 - 24	3000 litres/day
4 x AL-direct	3.5 bar	240 / 14,4	240 - 58	6000 litres/day

\*Note: The flow rates are approximate as they are highly dependent on the raw water quality and the clogging condition of the membrane.

## 7 Installation and commissioning

### Connections

#### **V1 - Inlet valve:**

Raw water is fed to this connection via a pressure pump or, in the case of geodetic applications, to the storage tank.

#### **V2 - Drain valve:**

This valve is only opened to drain the water when cleaning the membranes.

A drain hose (not included in the scope of delivery) can be connected to this connection.

The valve must be screwed in with sealant on site.

**Note:** Valve V1 and V2 can be interchanged in their function if this makes more sense for the installation ratio. The following description is based on the above assignment.

#### **V3 - Venting valve**

The bleed valve is opened during initial commissioning to allow air to escape from the filter housing (or for ventilation during maintenance) so that the water can drain away.

#### **V4 - Outlet valve**

The clear water pressure pipe system to the consumers is connected to this connection. When commissioning the filtration unit for the first time, the filter unit must be flushed (see Commissioning)

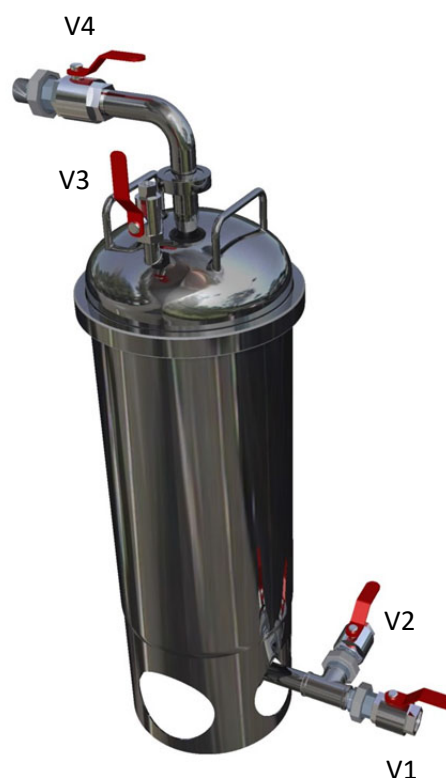

**Commissioning**

1. Close all valves except for inlet valve V1 and start the pressure pump
2. Carefully open vent valve V3 to allow the air to escape until water emerges. Then close vent valve V3 again.
3. Open the outlet valve V4 so that the filtered water can be pressed to the consumers. The AL-direct ultrafiltration unit is now ready for filtering.

**Note: When using the ultrafiltration unit for the first time, discard the first approx. 30 litres of filtered water until clear water comes out of the system. In this case, connect a hose to the outlet and drain the water, otherwise skip this step.**

## 8 Maintenance and storage

### 8.1 Mechanical cleaning

During mechanical cleaning, the particulate substances that adhere to the fibres from the outside are removed. This increases the volume flow again. If hot water is used for cleaning, a maximum temperature of 30°C must be maintained.

#### Cleaning steps for immersion cleaning in the housing:

1. Close all valves.
2. Open the vent valve V3 and the drain valve V2 to empty the filter housing.
3. Loosen the pipe compression fitting on the outlet valve V4 and open the cover compression fitting.
4. Open the housing cover and pull up the cover together with the membranes.
5. Close the drain valve and open the inlet valve V4 slightly until the housing is approx. 75 % full of water. Now move the cover with membrane up and down. This washing movement gradually removes the sludge from the membrane.
6. Drain and renew the water in between.
7. Ensure that all three membranes are also thoroughly cleaned inside the bundles. Do not damage any membrane fibres. If this does happen, simply knot any torn fibres at the end.
8. Re-insert the membrane bundles into the housing in reverse order. Before closing the cover, make sure that the union screws of the membrane bundles have not come loose.



**Cleaning steps for external cleaning with a garden hose:**

1. Close all valves.
2. Open the vent valve V3 and the drain valve V2 to empty the filter housing.
3. Loosen the pipe compression fitting on the outlet valve V4 and open the cover compression fitting.
4. Open the housing cover and remove the cover together with the membranes from the housing.
5. Place the cover/membrane in a washing tub. Use a garden hose (not a high-pressure cleaner) to carefully rinse the membrane fibres clean. Make sure that all three membranes are also thoroughly cleaned inside the bundles. Do not damage any membrane fibres. If this does happen, simply knot any torn fibres at the end.
6. Rinse the inside of the housing clean.
7. Re-insert the membrane bundles into the housing in reverse order. Before closing the cover, make sure that the union screws of the membrane bundles have not come loose.



## 8.2 Chemical cleaning

Intensive chemical cleaning of the membrane is only carried out if

- the filtration performance in the application has decreased too much despite mechanical cleaning
- the filter unit is to be stored until the next use
- the filter unit should be disinfected after storage and recommissioning

Dry cleaning is carried out in the following order

1. Citric acid solution and a subsequent clear water rinse (dissolves mineral deposits)
2. Chlorine solution and subsequent clear water rinsing (removes biological soiling and disinfects)
3. Alcohol solution (only if there is a blockage due to oil or grease) and subsequent clear water rinsing

### **NOTE!**



Never mix the citric acid solution with the chlorine solution, as toxic gases are formed!

All components must therefore be thoroughly rinsed with water after acid cleaning and before adding the chlorine solution!



Observe and follow the warning and safety instructions for the chemicals used! Protective gloves, protective clothing and safety goggles must be worn during the cleaning process!

We recommend mixing the cleaning solution with standard household cleaning agents as follows:

- 1) Acidic cleaning against precipitation, e.g. limescale with citric acid  
**Concentration of the cleaning solution 1% citric acid**
  - a.) Citric acid in powder form  
Dissolve 100 g per 10 litres of warm, clean water (30°C)
  - b.) Citric acid as a solution available in drugstores  
Add 200 ml per 10 litres of warm, clean water (30°C)
- 2) Alkaline cleaning against chlorine-based biofouling NHCl  
**Concentration of the cleaning solution 0.25% chlorine**
  - Observe the concentration and mix the cleaning fluid according to the mixing table below.



Base concentration Chlorine	Target concentration of the cleaning solution with chlorine	Water/chlorine mixing ratio
5%	0,25%	10 l / 1.05 l
10%	0,25%	10 l / 166 ml
15%	0,25%	10 l / 690 ml
20%	0,25%	10 l / 250 ml
25%	0,25%	10 l / 200 ml
30%	0,25%	10 l / 170 ml

### 3) Cleaning with alcohol against grease and for disinfection

#### **Alcohol concentration 75-98%**

- It does not have to be mixed with water, cleaning can be carried out in the concentrations specified above.

#### **Cleaning steps for cleaning with citric acid and chlorine:**

1. Fill the container with 5 litres of water and add a single dose of cleaning solution according to the dosing instructions. Then fill the container completely with a further 5 litres of water.
2. Immerse the membrane in this cleaning solution
3. Leave the membranes in the cleaning solution for a minimum of 2 hours and a maximum of 24 hours. During this time, move the membrane up and down several times so that the cleaning fluid is exchanged in the membrane fibres.
4. After the cleaning time, drain the cleaning solution into a channel via valve V2.
5. Rinse the system clean at least twice with 20 litres of water (two buckets) each time.
6. As with the initial start-up, the first 30 litres of the filtrate must also be discarded.

If the desired filtration performance is not achieved after chem. If the desired filtration performance is not achieved after dry cleaning, the cleaning process can be repeated.

#### **Cleaning steps for cleaning with alcohol (only if oil and grease are suspected):**

1. Fill the container with 10 litres of alcohol.
2. Immerse the membrane in the alcohol.
7. Leave the membranes in the cleaning solution for a minimum of 1 hour and a maximum of 24 hours. During this time, move the membrane up and down several times so that the cleaning fluid is exchanged in the membrane fibres.
3. After the cleaning time, drain the cleaning solution into a channel via valve V2.
4. Rinse the system clean at least twice with 20 litres of water (two buckets) each time.
5. As with the initial start-up, the first 30 litres of the filtrate must also be discarded.

### 8.3 Storage

New membrane units should be stored in their original packaging until final installation. The following storage conditions apply:

- Membrane units must be protected from direct sunlight
- Storage temperature between 10 - 30 °C at a relative humidity below 70%

Used membranes are mechanically and chemically cleaned and then rinsed. They can then be stored dry in accordance with the storage conditions.

**Note:**

**The special, hydrophilic membrane material makes it easy to recommission. The membrane material softens completely when reused in water. Caution: The fibres are brittle when dry!**

## 9 Spare parts and cleaning agents

Article description	Code	Art. no.
AQUALOOP membrane bundle 6m <sup>2</sup> *	AL-MEM6qm	230014
AL-direct gasket set Clamping ring seals, 1 xØ220mm and 2 x Ø50 mm	AL-Direct Gaskets	230019
Citric acid powder 0.35kg	AL-Acid0.35	230405
Chlorine cleaner 5%, 1.5 litres	AL-Chlor-5%-1.5L	230420

*\*After exceeding a service life of 10 years, the membrane bundles must be replaced.*

## 10 Guarantee

INTEWA GmbH provides a 24-month warranty for the ultrafiltration unit from the date of delivery. Please keep the proof of purchase as proof of this date.

Within the warranty period, INTEWA GmbH shall provide warranty at its discretion by repair or replacement.

The warranty does not cover damage caused by improper use, wear and tear or manipulation by third parties. The warranty does not cover defects that only insignificantly impair the value or usability of the appliance.

## 11 Contact us

### **For customers in Germany:**

Please contact INTEWA GmbH directly with any questions, spare parts orders and for servicing, quoting the appliance number and the purchase invoice.

INTEWA GmbH

Auf der Hüls 182

52068 Aachen

Germany

Phone: +49 241 96605 0

Fax: +49 241-96605 10

Email: [info@intewa.de](mailto:info@intewa.de)

Internet: [www.intewa.de](http://www.intewa.de)

### **For customers outside Germany:**

If you have any questions, need to order spare parts or require servicing, please contact your dealer or the general importer responsible for servicing, quoting the appliance number and the purchase invoice.

## Appendix

### Appendix 1.1 LOG reduction

Table: Determination of LOG reduction (LRV) by the University of Natural Resources and Life Sciences, Vienna

<b>Microbial Challenge Test</b>			
<b>AL membrane</b>			
<b>20.1 nm</b>			
Universität für Bodenkultur Wien / University of Natural Resources and Life Sciences, Vienna			
<b>Coliforms</b>			
Date	Raw water	after Filter 1	LRV
	/ 100 ml	/ 250 ml	
13.05.2017	321500	0	>5,89
<b>E.Coli</b>			
Date	Raw water	after Filter 1	LRV
	/ 100 ml	/ 250 ml	
13.05.2017	1492500	0	>6,57
<b>Enterococcus</b>			
Date	Raw water	after Filter 1	LRV
	/ 100 ml	/ 250 ml	
13.05.2017	304250	0	>5,88
<b>Pseudomonas aeruginosa</b>			
Date	Raw water	after Filter 1	LRV
	/ 100 ml	/ 250 ml	
22.05.2017	>1000	0	>3,40

## Appendix 1.2: Declaration of conformity of the membrane

**Chemie – Lebensmittelchemie**

**Biochemie – Mikrobiologie**

Chemisches Laboratorium Dr. Stegemann  
Leimbrink 2 – 49124 Georgsmarienhütte

**SFC Umwelttechnik GmbH**

Julius-Welser Str. 15  
A-5020 Salzburg

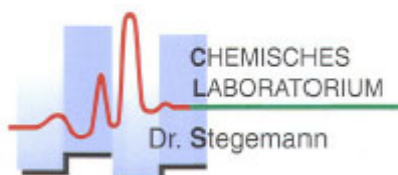

von der Industrie- und Handelskammer  
öffentlich bestellt und vereidigter Sachverständiger  
für Chemie insbesondere Chemie der Abfallstoffe,  
chemisch-physikalische Untersuchungen von  
Kunststoffen Ölen, Baustoffen, Korrosionen  
zuständig: IHK Osnabrück-Emsland-Grafschaft Bentheim

Wasser-Abwasser-Trinkwasser-Brauchwasser-  
Grundwasser-Boden-Lebensmittel-Hygiene-Bedarfs-  
gegenstände-amtliche Gegenproben-Abfälle-  
Abwasserkataster-Materialprüfung-  
Schadensgutachten-Beratung-

09.06.2017/stc

### Konformitätserklärung

**1279-117050258**

Seite 1 von 2

Hiermit erklären wir, dass das Produkt:

#### **Membranbündel PE-1700/400**

den Vorschriften der europäischen Kunststoff-Verordnung (EU) Nr. 10/2011 sowie der Verordnung (EU) Nr. 1935/2004 in der jeweils aktuellen Fassung entspricht.

Die Gesamtmigration sowie die spezifische Migration der Metalle nach der (EU) Nr. 10/2011 Anhang II Nr.1 sowie ausgewählte Metalle der Trinkwasserverordnung (TVO) liegen bei den von uns geprüften Kontaktzeiten, -temperaturen und Simulanzien unter den gesetzlichen Grenzwerten.

#### **Spezifikation des vorgesehenen Verwendungszweckes**

<b>vorgesehene Verwendung</b>	: Wasserreinigung/-aufbereitung
<b>vorgesehen Kontaktmaterialien, für die die Konformität bestätigt werden kann</b>	: Wasser/Trinkwasser
<b>zugehörige Simulanzlösemittel</b>	: Ethanol 10 % (Simulanz A)
<b>zugehörige Prüfbedingungen der Globalmigration für, die die Konformität bestätigt werden kann</b>	: 10 min bei 20 °C (modifiziert nach realen Prozessbedingungen)
<b>zugehörige Prüfbedingungen der spezifischen Migration für, die die Konformität bestätigt werden kann</b>	: 10 min bei 20 °C (modifiziert nach realen Prozessbedingungen)
<b>Untersuchungszeitraum</b>	: 10.05.2017 - 31.05.2017

#### **Akkreditiertes Prüflabor**

Kommunikation:  
Tel. +49 (5401) 8636-0  
FAX +49 (5401) 8636-36  
e-mail: info@labor-stegemann.de  
Internet: www.labor-stegemann.de



Chemisches Laboratorium Dr. Stegemann  
49124 Georgsmarienhütte

Fortsetzung der Konformitätserklärung vom 09.06.17

### Untersuchungsergebnisse

Simulanz	Globalmigration mg/dm <sup>2</sup> DIN EN 1186-1-3 F / V = 5	Grenzwert mg/dm <sup>2</sup>
Ethanol 10 %	8,5	10

Simulanz Ethanol 10 %	Spezifische Migration mg/kg F/V = 5	Grenzwert VO (EU) 10/2011 mg/kg
Aluminium	< 0,5	1
Barium	< 0,4	1
Cobalt	< 0,05	0,05
Kupfer	< 0,1	5
Eisen	< 7	48
Lithium	< 0,5	0,6
Mangan	< 0,5	0,6
Zink	< 0,9	5
	Messwert im Simulanz mg/l	Grenzwert TVO mg/l
Quecksilber	< 0,001	0,001
Chrom	< 0,02	0,05
Cadmium	< 0,002	0,003
Blei	< 0,005	0,01
Silanole (Monomer)	< 1	--



Dr. Dirk Stegemann  
- Prüfleitung-

von der Industrie- und Handelskammer öffentlich bestellt und vereidigter Sachverständiger für Chemie, insbesondere Chemie der Abfallstoffe; chemisch-physikalische Untersuchungen von Kunststoffen, Ölen, Baustoffen, Korrosionen  
zuständig: IHK Osnabrück-Emsland-Bad Bentheim

vom niedersächsischen Landesamt für Lebensmittelsicherheit und Verbraucherschutz zugelassener Gegenprobensachverständiger nach § 43 LFGB für chemische und mikrobiologische Untersuchungen von Lebensmitteln und Bedarfsgegenständen aller Art