

INTEWA



BELGAQUA



RAINMASTER Favorit-SC

Installation and user manual

WATER WE'RE IN OUR ELEMENT

Table of contents

1. Introduction and scope of application	2
1.1 Modes of operation	3
2. Safety instructions	5
3. Scope of delivery	6
4. Technical Data	7
4.1 Device overview and dimensions	8
4.2 Dimensions of the intake line	9
4.3 Standards, directives, tests	10
4.3.1 Secure separation Categorie 5 according EN 1717	10
4.3.2 EU - Konformitätserklärung	11
5. Overview of components	12
5.1 Components of the pump-controller	12
5.1.1 Description of display and buttons	12
5.1.2 Cable connection plan	14
5.1.3 Self-initialization check	15
5.1.4 Advanced regulations / settings mode	16
5.2 Components of basic controller	20
5.3 Components of the multistage pump	22
5.4 Components of supplemental supply	23
5.5 Components of the electronic 3/2-way ball valve	23
6. Installation instructions	24
6.1 Wall mounting	24
6.2 Connection to the mains water line	25
6.3 Installations on the suction side	26
6.3.1 Installation of a protective conduit pipe	26
6.3.2 Layout of the intake line	27
6.3.3 Intake line connection	28
6.3.4 Installation of the floating intake	28
6.4 Installation of the pressure line set	29
6.5 Connecting the emergency overflow	30
6.6 Installation and adjustment of the float switch	31
7. Start up and use	32
7.1 Start-up in mains water mode	32
7.2 Start-up in rainwater mode	33
7.3 Modes of operation and display	35
7.3.1 Automatic mode (Switching position I)	35
7.3.2 Maintenance mode (Switch position II)	36
8. Safety monitoring and error notifications	36
9. Troubleshooting	37
10. Maintenance	39
11. Spare parts	39
12. Optional Accessories	39
13. Guarantee	40
14. Contact / Unit serial number	40
Annex 1.0 Scope of duplex or triplex application	40
Annex 1.1 Intake variants	41
Annex 1.2 Technical data for duplex- and triplex-application	44
Annex 1.3 Group function via Bluetooth by duplex and triplex applications	45
Annex 1.4 Parameter adjustment F17	45

1. Introduction and scope of application

Congratulations on purchasing your **RAINMASTER Favorit-SC** (*RM Favorit-SC*).

The RM Favorit-SC is specially designed for water harvesting (e.g. rain water, grey water or cooling water) in large single family dwellings, multiple family dwellings and in commercial and industrial applications.

The maximum installation height for consumers above the RM Favorit-SC 20 is 20 m and above the RM Favorit-SC 40 is 30 m.

The application range can be enlarged by a series up to three RM Favorit-SC. The plant control system is realised by wireless Bluetooth.

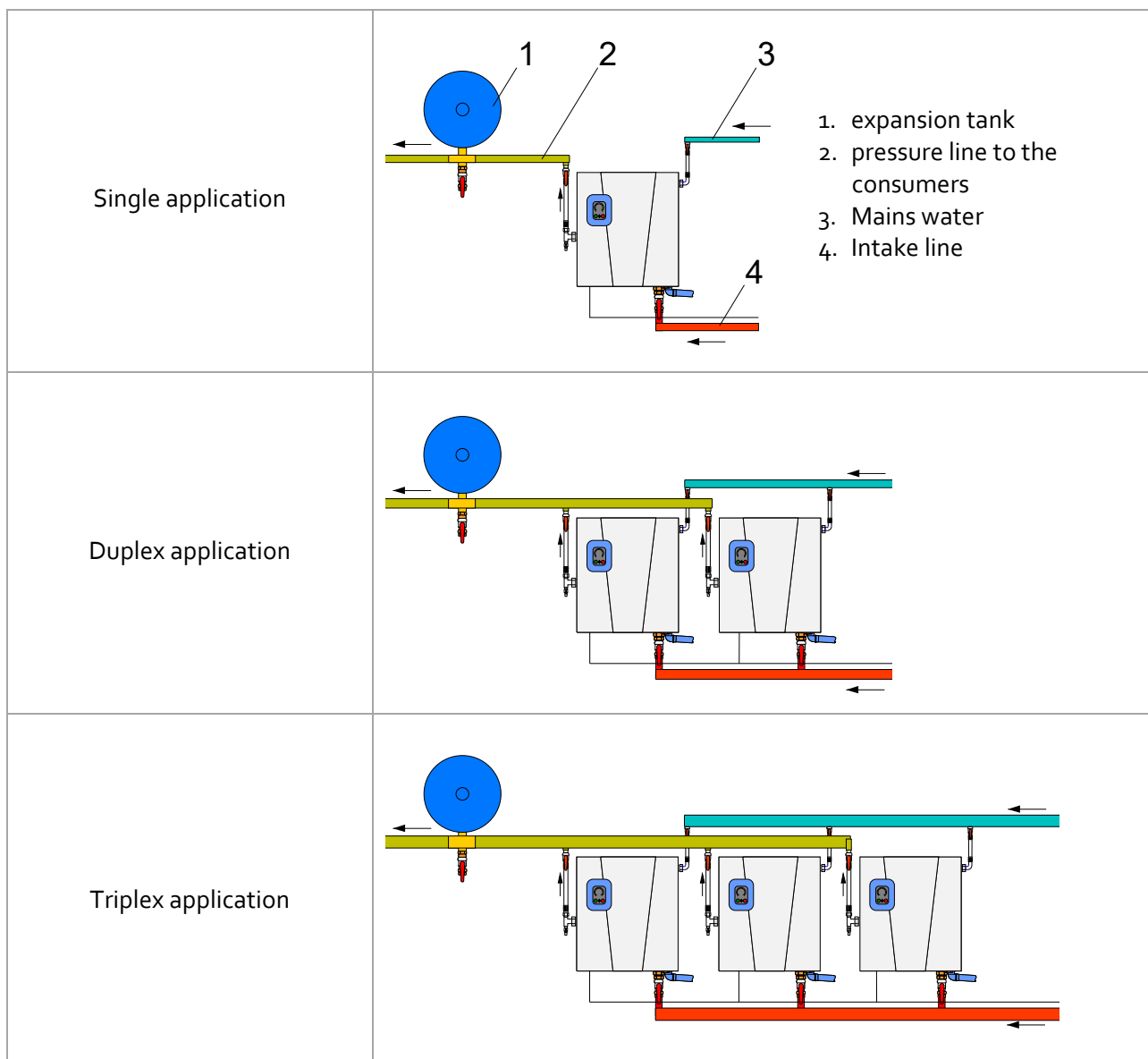

1.1 Modes of operation

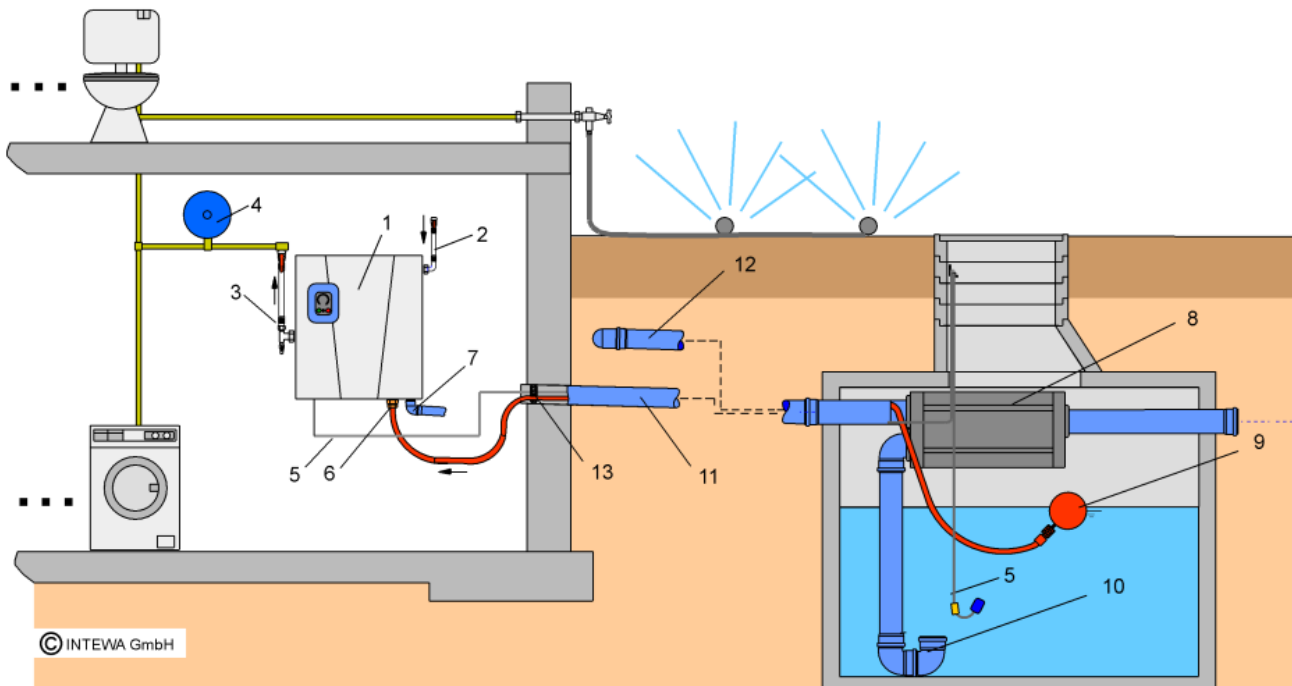

An example of a rainwater harvesting system with external storage and RM Favorit-SC

- | | |
|-------------------------------------------------|---------------------------------------------------------------|
| 1. RAINMASTER Favorit-SC | 8. PURAIN rainwater filter |
| 2. Mains water connection | 9. Floating intake filter model SAUGSAGF |
| 3. Pressure line set with air vent and stopcock | 10. Quiet inflow |
| 4. Pressure line to house with expansion tank | 11. Protective conduit pipe for suction line and sensor cable |
| 5. Float switch cable | 12. Rainwater line into the tank |
| 6. Suction line | 13. MD100 wall bush |
| 7. Emergency overflow | |

Automatic mode

In Automatic mode, the pump carries rainwater from the tank into the home and onto respective applications (e.g. toilets etc.). If the tank is empty, this is detected by the float switch in the tank, which instructs the electronic 3/2-way ball valve to change to the mains water mode. The rainwater intake line is then blocked and the required mains water is sourced from the built-in supplemental supply container inside the *RM Favorit-SC*. After it rains, and the tank is topped-up with rainwater again, the float switch detects this and the electronic 3/2-way ball valve switches back to the rainwater intake setting.

Maintenance mode

In maintenance mode, the electronic 3/2-way ball valve stays permanently switched to mains water mode, and the house is continuously supplied with mains water from the supplemental supply container inside the *RM Favorit-SC*.

Speed control

In both modes (automatic/maintenance), the speed of the centrifugal pump is controlled by a frequency converter corresponding to the set pressure level. The pressure is monitored via a built-in analog pressure sensor. The current is monitored via the power controller. This 100% ensures that the pump never runs dry. All operating parameters such as delay time, idle and load power consumption and response time for the running dry are specified by the controller.

Bluetooth connection

Two to three series of *RM Favorit-SC* can communicate with each other without any wires via the integrated Bluetooth and can be conveniently combined in a fully redundant multiple pumping system. The pairing, the cyclic switching of the pumps, the connection with peak load and the Master/Slave exchange is done automatically in case of the failure of device.

2. Safety instructions



The live components have to be installed only by a qualified electrician. In case of failure of the electronic device, the product has to be repaired by a qualified electrician before being operated again. There is a risk of electric shock!

The outlet circuit used for the device has to be secured through a circuit breaker protected (16 A in several countries). If unavailable, an FI switch with maximum operating current of 30 mA has to be connected.



These installation and operating guidelines have to be read carefully before installing the product. The instructions mentioned have to be followed strictly. Modifications to the product are not permitted, otherwise the warranty becomes void.

- The following points have to be strictly observed during the installation and operation:
- Check the product before installation for any visible defects. If defects are present, then the product must not be installed. Damaged products can be dangerous.
- Installations at the drink water pipeline system have to be only performed by a qualified installation firm.
- A floor drain has to be provided near the installation site, which can collect inadvertent water discharge (such as with pump defect, pipe breakage etc.) and prevent water damage inside the building.
- The brickwork behind the water-carrying system must be protected from water (such as with water-resistant paint).
- Make sure that the existing emergency overflows are connected and adequately sized.
- Remove the mains plug if you will be away for more than 24 hours. Lock the fresh water line at the inlet of the device if you will be away for more than 24 hours
- All products must be regularly inspected to maintain proper condition. The minimum inspection interval is mentioned in the maintenance manual.
- Electric devices may be hazardous for children. Therefore children always have to be kept away from the product. Do not let children play with the product.
- Do not install the water-carrying products in locations where the temperature may drop below 0°C.
- Do not install any electric products in flood-prone areas.
- The operator is responsible for adherence of the safety and installation guidelines.

3. Scope of delivery

RAINMASTER Favorit-SC unit



Wall mounting material and installation and user manual



Standard accessory A
(Mains water connection):



Standard accessory B
(Pressure line set):



Standard accessory C
(Float switch):



4. Technical Data

	RM Favorit-SC 20	RM Favorit-SC 40
Dimensions (H x W x D):	595 x 550 x 265 mm	595 x 550 x 265 mm
Weight:	33 kg	34 kg
Nominal power supply input / power frequency:	230 V AC / 50-60 Hz	230 V AC / 50-60 Hz
Max. power rating:	max. 0,8 kW	max. 1,35 kW
Max. power intake:	max. 3,7 A	max. 6,2 A
Operating pressure:	2,0 - 4,5 bar (adjustable)	2,0 - 6,0 bar (adjustable)
Max. volume flow rate:	90 l/min	130 l/min
Noise level:	35 - 60 dBa	35 - 65 dBa
Intake height (self-priming):	0 - 4m (see intake diagram)	0 - 4m (see intake diagram)
Protection class:	IP 54	IP 54
Max. mains water pressure:	2,5 - 6 bar	2,5 - 6 bar
Highest consumer above RM Favorit:	20 m	30 m
Float switch:		
Cable length x Cross section:	15 m x Ø9 mm, (3 x 1,0mm ²)	15 m x Ø9 mm, (3 x 1,0mm ²)
Protection class:	IP68	IP68

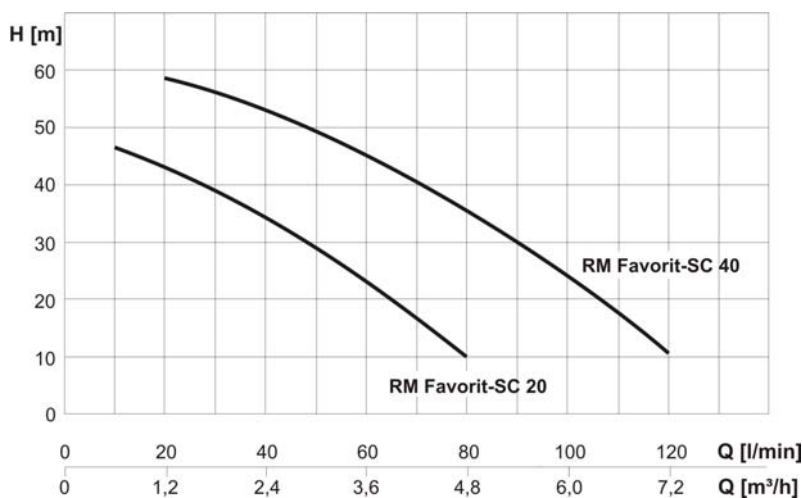

Performance curve of the pump

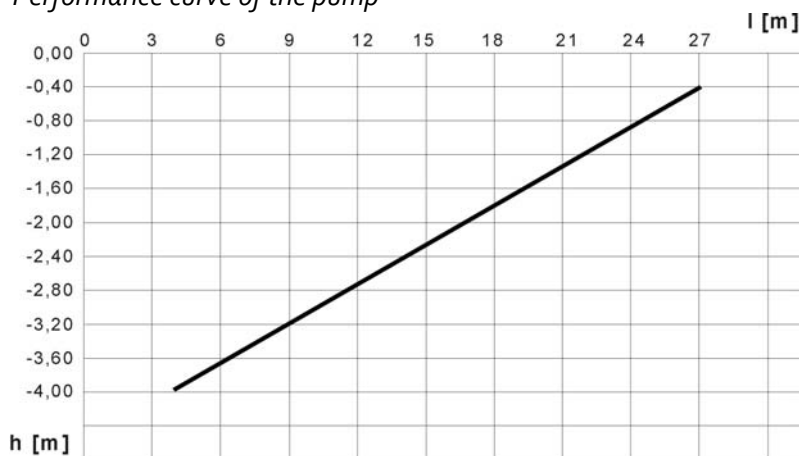

Performance curve of the intake for RM Favorit-SC 20/40

4.1 Device overview and dimensions

View from right

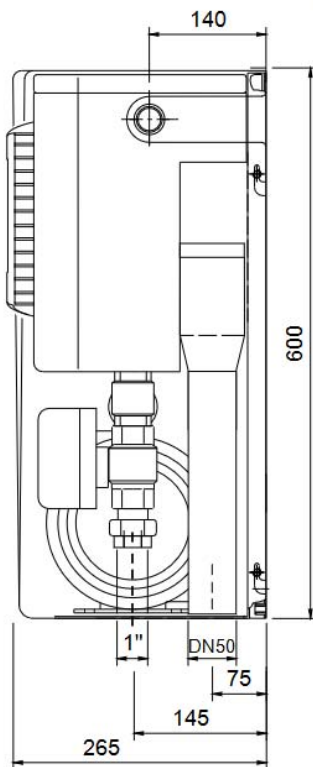

Front view

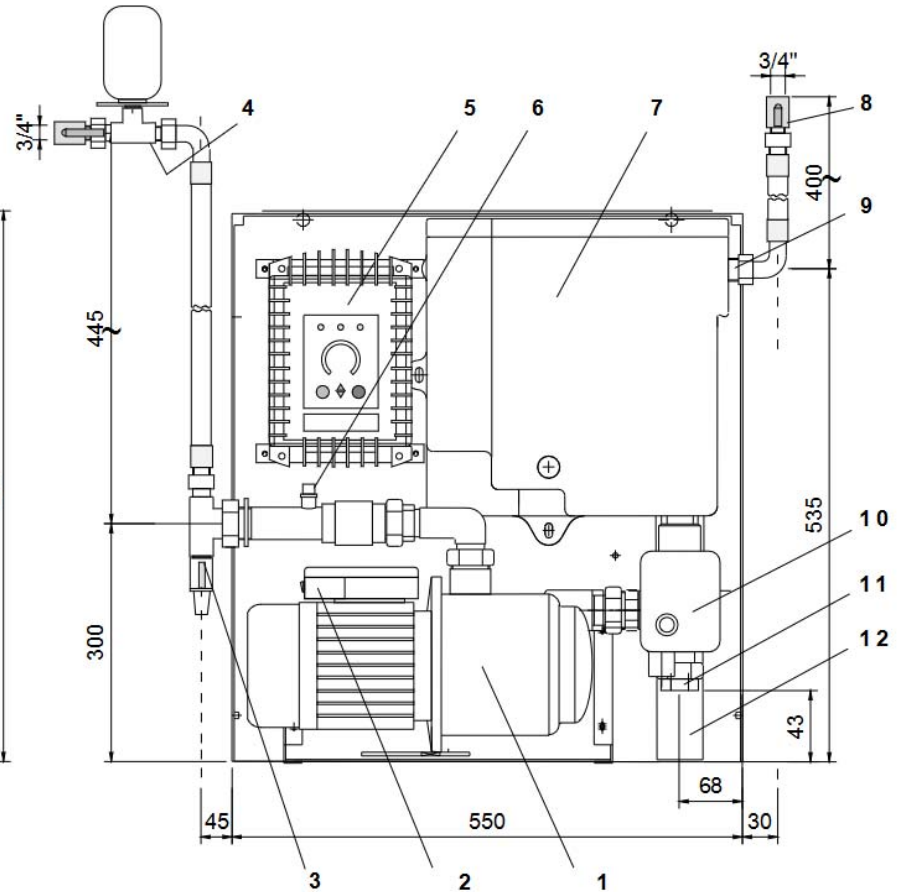

View from left

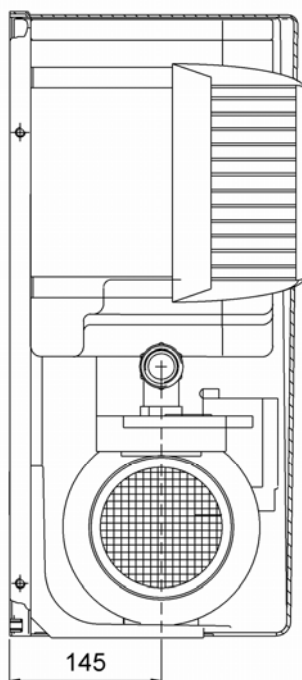

1. Multistage pump RM Favorit-SC 20 / 40
2. Pump terminal box with basic controller
3. Vent cock
4. Pressure vessel and shut-off valve
5. Pump-controller (speed control)
6. Pressure sensor 4-20 mA, 1/4" male
7. Supplemental supply container
8. Stopcock for mains water (3/4" female)
9. Mains water floating valve
10. Electronic 3/2-way ball valve with display
11. Intake line (1" female)
12. Emergency overflow line DN 50 (Ø 55mm)

4.2. Dimensions of the intake line

In practice, the self-priming function of the pump depends due to decrease in pressure (pipe friction, suction level) only in a certain range. In this operating range, the pump can evacuate the air out of the suction line (for example, with initial start-up operation). The performance curve of the intake line indicates the dependence of intake length on the intake level. The determined value is above the represented intake line in the diagram. If the intake point is below the intake performance line, then a hybrid tank with charging pump is necessary (see Annex 1.1).

Sample dimensions:

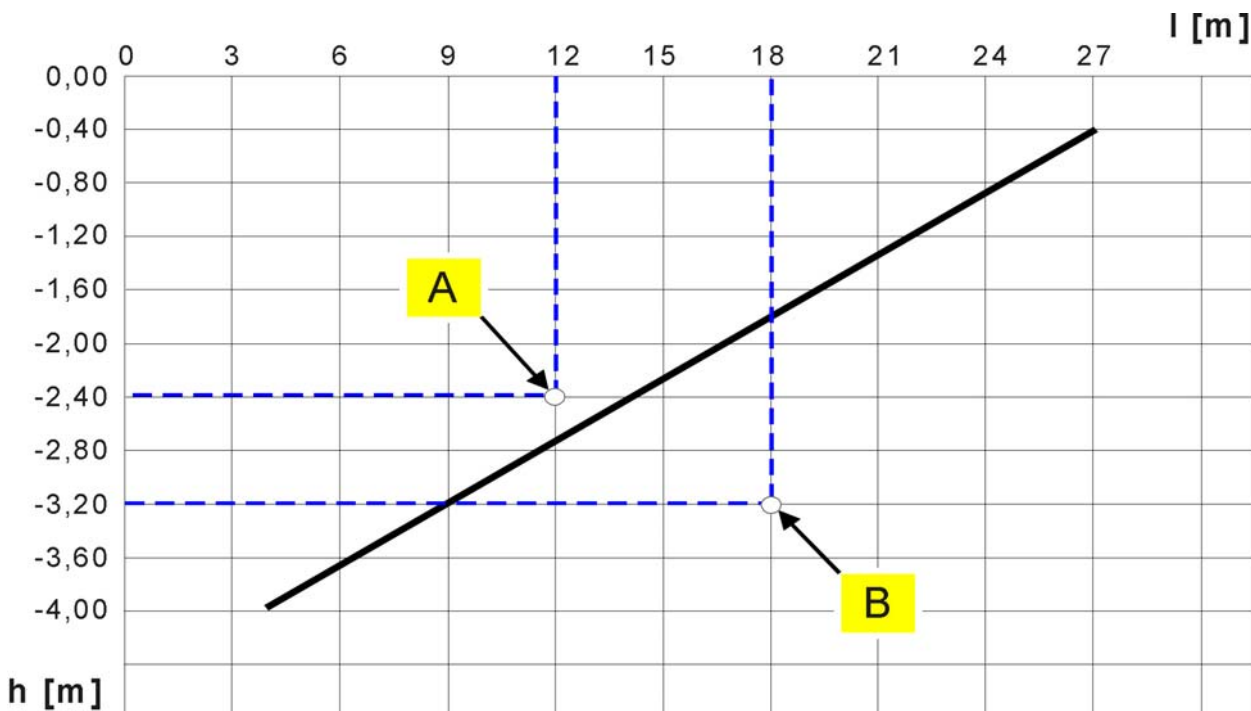

Example A:

Length of suction pipe: = 12 m

Intake level: = 2.40 m (Height difference between deepest intake level and pump)

→ o.k. because it's above the performance curve

Example B:

Length of suction pipe: = 18 m

Intake level: = 3.20 m (Height difference between deepest intake level and pump)

→ not o.k. because it's below the performance curve

→ hybrid tank with charging pump is required (see Annex 1.1)

4.3 Standards, directives, tests

4.3.1 Secure separation Categorie 5 according EN 1717

The *RM Favorit-SC* meets the DIN 1989-4 "Components for Control and Supplemental Supply" standards for rainwater harvesting systems. The DVGW mark of approval confirms the presence of the mandatory "air gap" (as per DIN EN1717) for secure separation of processed water from the mains water line, which is integrated into the RM Favorit SC.

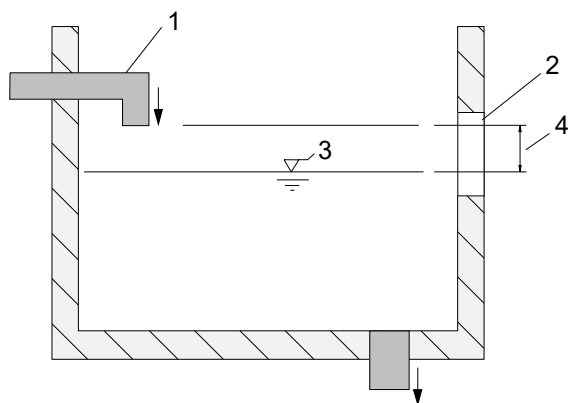

1. Mains water inlet (floating valve)
2. Emergency overflow
3. Max. water level (in case of malfunction)
4. Air gap between inlet and max. possible water level = secure separation of mains water and processed water

Mains water supplemental supply device, Type AB as per DIN EN 1717

Mains water supplemental supply device:	  
Mains water supplemental valve: WRAS mark certified	

4.3.2 EU - Konformitätserklärung

Diese EU-Konformitätserklärung wurde in alleiniger Verantwortung von INTEWA GMBH ausgestellt.

This declaration of conformity is issued under the sole responsibility of INTEWA GmbH.

Dokument-Nr.: 03/10/2021

Document-No.:

Hersteller: INTEWA GmbH

Manufacturer:

Anschrift:

Address:

Auf der Hüls 182

D – 52068 Aachen

Produktbezeichnung: Pumpenstation

Product designation:

pump station

Typenbezeichnung:

Type:

RM-Fxx, SMT-Fxx

Der oben beschriebene Gegenstand der Erklärung erfüllt die einschlägigen Harmonisierungsrechtsvorschriften der Union:

The object of the declaration described above is in conformity with the relevant Union harmonization legislation:

2006/42/EU: Maschinenrichtlinie

2006/42/EU: Directive Machinery

2014/30/EU: EMV Richtlinie

2014/30/EU: Directive relating to electromagnetic compatibility

2011/65/EU: RoHS-Richtlinie II

2011/65/EU: RoHS Directive II

2015/863/EU RoHS-Richtlinie III

2015/863/EU RoHS-Richtlinie III

Angewandte harmonisierte Europäische Norm:

Applied harmonised European Standard:

EN60335-1:2012/A11:2014:2014/A13:2010/A15:2011, ENISO 12100:2010

EN 61000-6-3:2007/A1:2011, EN 61000-6-1: 2007, EN 61000-6-4: 2007/A1:2011

EN 61000-6-2: 2005, EN55014-1:2006/A2:2011

EN50581:2012

Weitere normative Dokumente

Other normative documents

EN 60335-2-41:2003/A2:2010

Ort, Datum: Aachen, 12.10.2021

Place, Date:

Rechtsverbindliche Unterschrift:

Legal signature:



Geschäftsführer Oliver Ringelstein
Manager

5. Overview of components

The *RM Favorit-SC* has a modular design. Each component can be separately changed.

5.1 Components of the pump-controller

The pump controller (see image chapter 4.1) monitors the pressure in the pressure line and maintains it at a constant level by speed controller. The controller reduces the power consumption, especially with small volume flow rate and increases the service life of the pump.







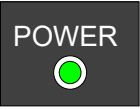

1. Motor pump OUT, 3-phase
2. Pressure sensor (4-20 mA output), 1/4" male
3. Power supply 230 V AC/50Hz

5.1.1 Description of display and buttons

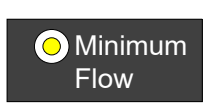
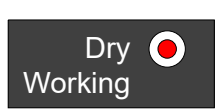
Button	Description
	<ul style="list-style-type: none"> - increases the working pressure (reference pressure) by 0.5 bar per keystroke (possible at any time during operation) - allows to go up on the advanced regulation functions also
	<ul style="list-style-type: none"> - reduces the working pressure (reference pressure) by 0.5 bar per keystroke (possible at any time during operation) - allows to go down on the advanced regulation functions also
	<p>START</p> <ul style="list-style-type: none"> - starts Self-Regulation-Test on the first installation or after a RESET
	<p>STOP</p> <ul style="list-style-type: none"> - instant Stop of the motor pump



Circular Led indication	Description
	<p>Power Green fixed: Inverter voltage supply is ON</p>
	<p>Pump ON Green fixed: Pump ON Green flashing: Enable OFF condition</p>
	<p>ALARM Red fixed: Pump stop for a problem that need manual restart (STOP then START) Red flashing: Pump stop for a problem with auto re-start</p>
	<p>Minimum Flow Yellow fixed: Pump stop for minimum output flow (s. F1) Yellow flashing: Pump is stopping for minimum flow(s. F14)</p>
	<p>Dry Working Red flashing: Pump stop for dry working condition of the pump, during one of four re-start of this problem, separated from 15 minutes Red fixed: final stop after 5th consecutive stop for this problem</p>
	<p>Circular LED indication</p> <ul style="list-style-type: none"> - manometer shape to indicate the instant pressure(0,5bar steps) - indication of the adjust pressure range about until 3 seconds after pressing <p> or </p> <ul style="list-style-type: none"> - Settings indicator in setting mode - In ALARM condition to each led corresponds a different type of alarm

5.1.2 Cable connection plan

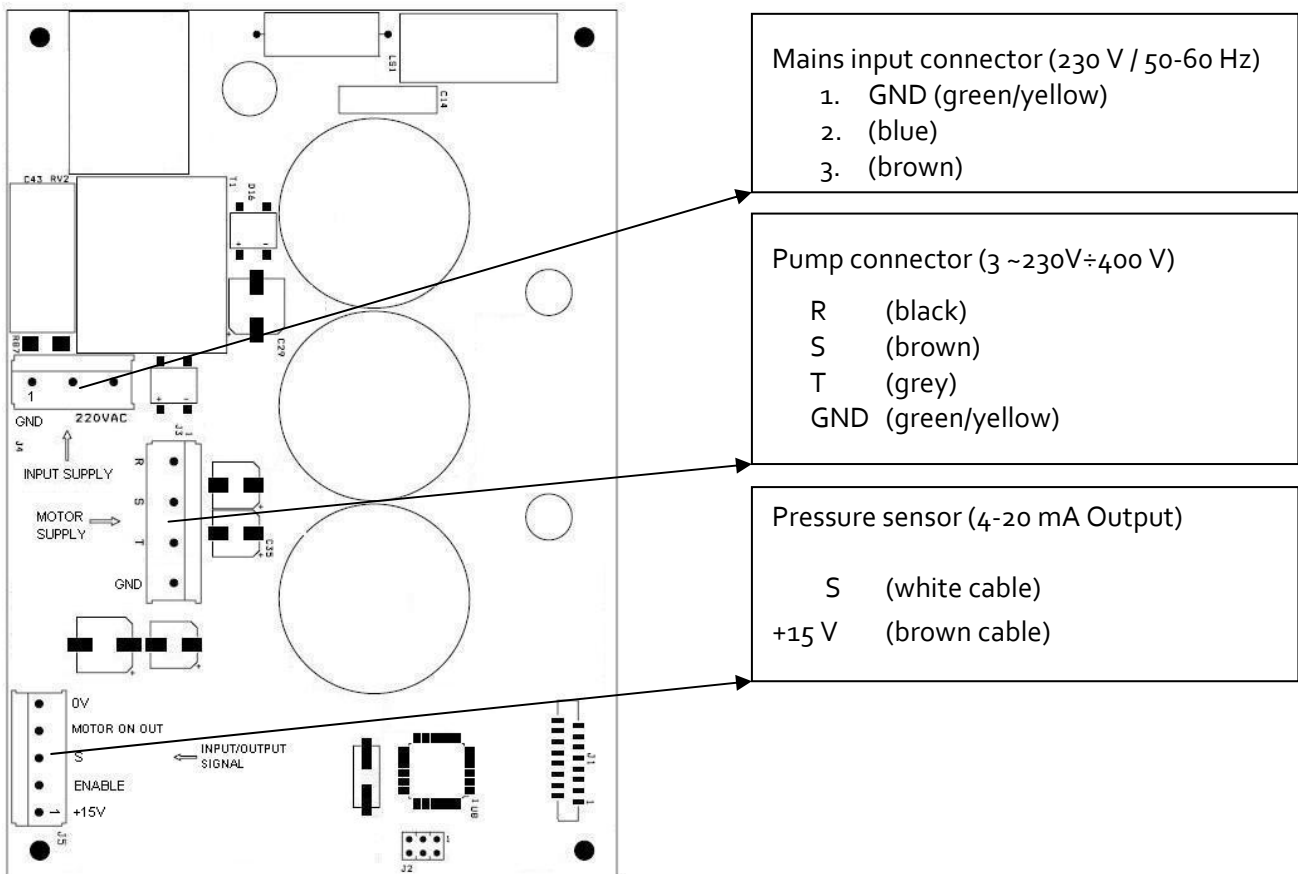

In the event of a damaged cable or faulty pressure sensor, it is necessary to open the housing of the pump control. For this purpose, the mains plug must be disconnected and you have to wait for at least 2 minutes until all LEDs turn off (internal capacitors are discharged). You may open the case only after this. For this purpose, you have to demount the complete pump control from the angle holders. Then the rear screws of the heatsink can be opened.

5.1.3 Self-initialization check

The pump controlled is pre-installed in the respective pump with *RM Favorit-SC!*



The below mentioned self-initialization must be performed **only** when a program RESET is conducted or if a new pump or a new pump control system is installed.



During this automatic initialization, the characteristic current values are processed at different operating parameters, which form the basis of the speed controller.

- 1.) Make sure the pump is primed with water (see chapter 7.1) when starting the pump for the first time.
- 2.) Open the air valve and water fill the system until there is no more air coming out. Then, close the pressure shut-off valve (pressure will build).
- 3.) In case the pressure in the system is > 3 bar on the LED display, open the air valve again to reduce the pressure to < 3 bar.

4.) Press  to start the self-initialization check. After about two minutes (total pressure range of the pump will be tested), the initialization is finished. The LED display lights up once completely, from 0 to 10 bar together and the pump starts (LED „Minimum Flow“ lights up).

5.) The self-initialization check is now finished and the start-up operation can follow (see chapter 7.2). Changing the predefined operating pressure of 3 bar is only possible, if necessary, in 0,5 bar steps by

pressing the  or  button. (If the LED indicator doesn't blink anymore, the pressure value has been saved

Command	Button combination
RESET (to restore constructor data)	 &  press them simultaneously for 5 seconds (Led indication total blinking for one time). Then pull the power supply plug and wait until there is no LED indication!
Starting SELF-INITIALIZATION	Plug in the power supply. Press  to start the self-initialization.

Checking the pump stop for delivery closed

At the end of the self-initialization check, done with the delivery of the pump completely closed (all of the output valves closed) the pump shall be automatically stopping and the Inverter could show the message "MINIMUM FLOW" by the corresponding yellow LED. The stop is preceded by a phase of flashing LED "MINIMUM FLOW". Verify that the pump stopped and after that the pump restart working when opening any valve on pump delivery.

Checking the arrest of the pump dry running

After installing, if possible, close the water input of the pump and check that, after approximately 40 seconds, the pump stops and shows the message "DRY WORKING" with corresponding red LED.







5.1.4 Advanced regulations / settings mode

In default setting, the parameters are adjusted on the pump of RM-F SC. However, it has an option of changing precise parameters in the settings mode.





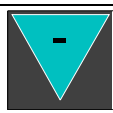

5.1.4.1 Parameter settings

Attention!

This should only be performed by an experienced skilled technician.

Command	Button combination
Activate the Settings Mode	 &  press them simultaneously for 3 seconds until the LED indication completely is blinking for a short moment and the regulation of F1 is shown on the Led indication.
Retrieve next setting parameter	Keep the  button pressed. By pressing  , the next setting parameter is selected. By releasing the buttons, the current setting parameter is displayed.
Change setting parameter value	By pressing  or  a value is increased or decreased. (The LED display indicates up to 20 steps.)
Confirm the setting parameters	By pressing  , you confirm the settings and exit the settings mode.

N.	Visualization	Advanced Function	Description	Range	Default
F1		Minimum flow stop	Adjustment of the minimum flow before pump stops.	0...+10 Step: 1	50%
F2		Maximum motor current	Adjustment of the limit value for overcurrent. RM-F20-SC: 3.0 A RM-F40-SC: 3.5 A	1...7 A Step: 0.5 A	7 A
F3		Minimum motor velocity	Adjustment of the minimum motor velocity (Reference nominal velocity of 2850 min ⁻¹).	30..70% Step: 2%	50%
F4		Maximum Motor Velocity	Adjustment of the maximum motor velocity (Reference nominal velocity of 2850 min ⁻¹).	90..110% Step: 1%	105%
F5		Rotation direction	Switch the direction of impeller rotation. Not necessary for use.	0/1	0
F6		Maximum starting acceleration	Adjustment of acceleration during pump start-up.	1000-10000 RPM/s Step: 500	3000 RPM/s
F7		Maximum operating pressure	Adjustment of operating pressure that cannot be exceeded by system.	2 ...10 bar Step: 0.5 bar	10 bar
F8		Pressure Hysteresis	Adjustment of the pressure hysteresis. Hysteresis is the differential needed for pump start-up.	0.15 ..1 bar Step: 0.05 Bar	0.3 bar
F9		Pressure acceleration / deceleration	Adjustment of the pressure acceleration while increasing/decreasing.	0.1 .. 2 bar/s Step: 0.1 bar/s	1 bar/s
F10		Pressure sensor minimum output signal	Adjustment of the minimum output value of the pressure sensor.	1..5 mA Step: 0.2 mA	4 mA
F11		Pressure sensor maximum output signal	Adjustment of the maximum output value of the pressure sensor.	10.. 20 mA Step: 0.5 mA	20 mA
F12		Pressure sensor range	Adjustment of the pressure sensor operating range.	10..20 bar Step: 0.5 Bar	16 bar

F13		Proportional P.I.D. factor	Proportional factor on the P.I.D. pressure control.	0..6000 Step: 300	3000
F14		Integral P.I.D. factor	Integral factor on the P.I.D. pressure control.	0..4000 Step: 200	1000
F15		Minimum flow stop delay	Delay time on the minimum flow condition before stopping pump.	2..20 sec Step: 1 sec	12 sec
F16		Dry running stop delay	Delay time on the dry running condition before stopping pump.	10..100 sec Step: 5 sec	40 sec
F17		Master-Slave Bluetooth	Operating mode with 1, 2 or 3 pumps with Bluetooth connection.	1: one pump 2: two pumps MASTER/SLAVE 3: three pumps MASTER/SLAVE	2
F18		Check parameter	Refers to the graph of the power consumption.	0: Theoretical curve 1: Self-initialization 2: Curve tested	1
F19		Measurements	Measures of different parameters.	0: Pressure (0..10 bar) 1: Frequency (15..55) 2: Current (0..10) 3: Voltage (200-240) 4: T [°C] (70..90) 5: Last alarm 6: Motor ΔT [°C](0..100)	0
F20		Radio Frequency transmission/reception	Frequency of transmission/reception of the radio communication between 2 or 3 controllers	780 ... 820 MHz Step: 1 MHz	800 MHz

5.1.4.2 Configured settings

Parameters F1 and F8 are delivered from the warehouse already with other configured settings. Parameter F17 is as well set to single pump operation. Applications with 2 or 3 pumps operating with Bluetooth means parameter F17 must be adjusted.

After a self-initialization the parameters are automatically set back to the defaults. The configured settings must be reset manually.

No.	LED-parameter menu	Function	Default setting	Configured setting
F1		Minimum flow stop	 Step: 10 (Display = 5.0)	 Increase: + 7 steps (Display = 8.5)
F8		Pressure Hysteresis	 Step: 6 (Display = 3.0)	 Increase: + 10 steps (Display= 8.0)
F17		Master-Slave Bluetooth	 (Two pumps) Step: 2 (Display = 1.0)	 One pump Reduce: -1 step (Display = 0.5) or Three pumps Increase: + 1 step (Display = 1.5)

5.2 Components of basic controller

The unit's basic controller is located in the terminal box of the pump. All the electronic components of the *RM Favorit-SC* are connected here. On the side of the terminal box is the mode selection switch I/II (position [1]) for Automatic and Maintenance mode. (see chapter 7.3 for functional description)

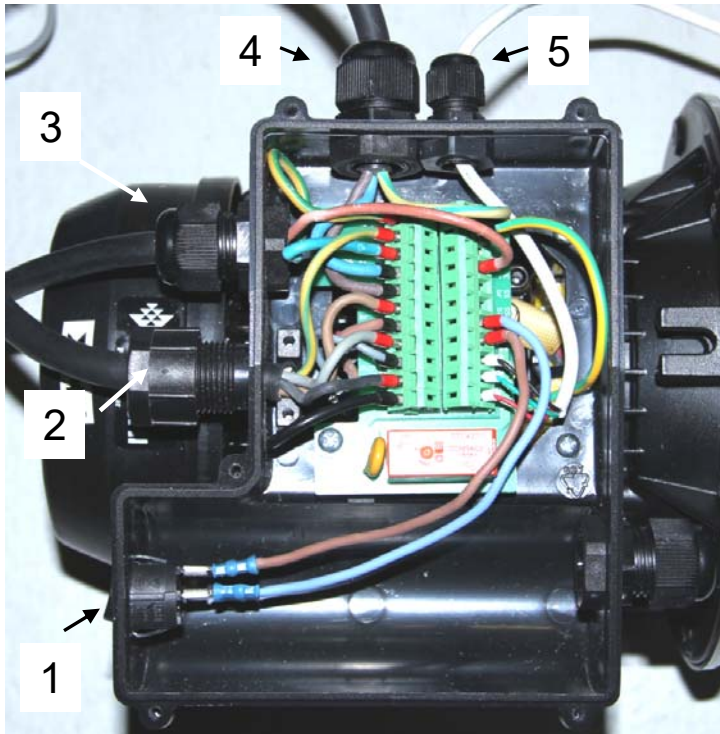

1. Selection switch
2. Pump control OUT, 3-phase
3. Mains connection ~230V AC/50 Hz
4. Mains pump control
5. Connection motorized ball valve

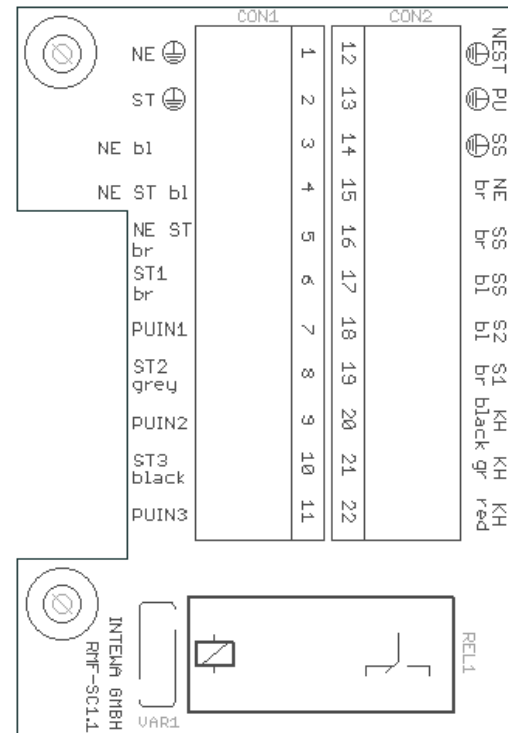

item	Board inscription	Description of connection
1	NE PE	Protective conductor mains connection
2	ST PE	Protective conductor pump controller
3	NE bl	N-Mains connection 230V~, blue
4	NE ST bl	N-Mains,Pump controller blue
5	NE ST br	L1-Mains,Pump controller brown
6	ST1 br	OUT-Pump controller brown
7	PUIN1	IN-Pump brown
8	ST2 grey	OUT-Pump controller grey
9	PUIN2	IN-Pump grey
10	ST3 black	OUT-Pump controller black
11	PUIN3	IN-Pump black

item	Board inscription	Description of connection
12	PU PE	Protective conductor pump
13	SS PE	Protective conductor floating switch
14	ST PE	Protective cond. pump controller
15	NE br	L1-Mains connection 230 V~, brown
16	SS br	Floating switch brown
17	SS bl	Floating switch blue
18	S2 bl	Selection Switch blue
19	S1 br	Selection Switch brown
20	KH black	Ball valve black
21	KH gr	Ball valve green
22	KH red	L1-Ball valve red

Table: Overview of the cable connections

Floating switch preparation	/Selection switch	Electrical contact

Table: Electrical switching conditions of the floating switch and selection switch

The mode selection switch is wired with a flat pin plug.

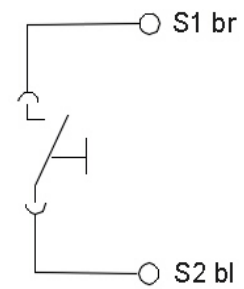

5.3 Components of the multistage pump

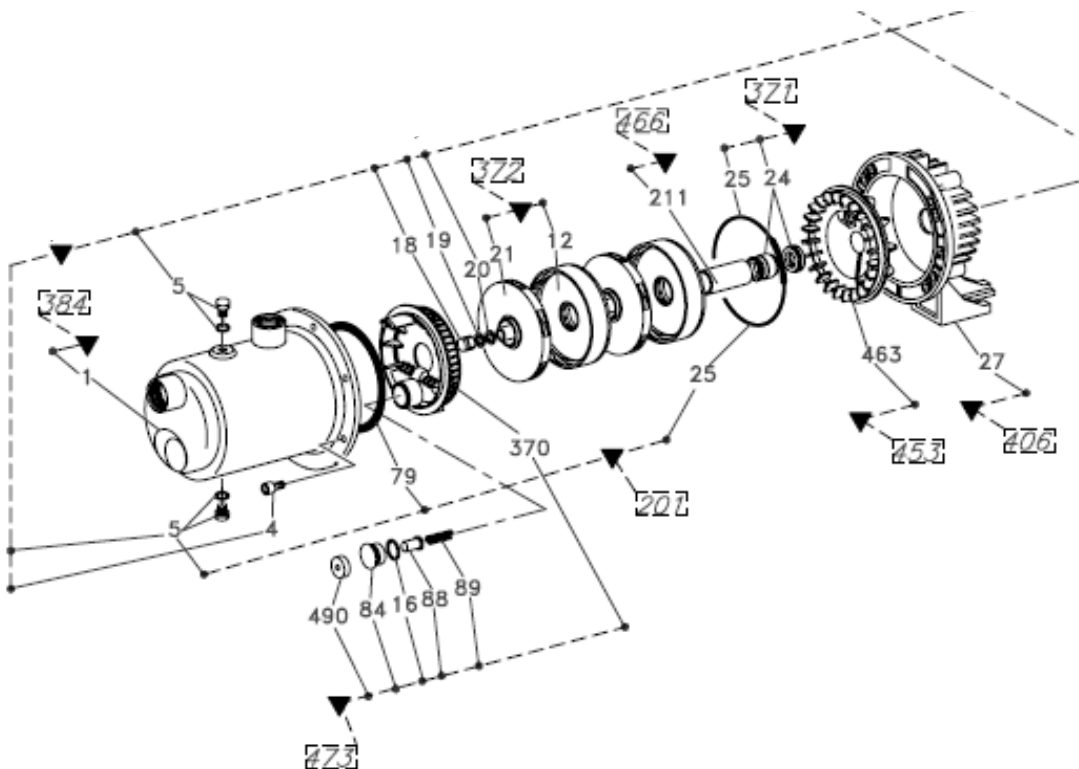

Expanded view of *RM Favorit-SC 20/40* centrifugal pump

KIT REF.	Nr. KIT DESCRIPTION	REF.Nr	COMPONENT DESCRIPTION	RM F 20 RM F 20-A SMT F 20	RM F-SC 20 SMT F 20	RM F 40 RMF 40-A SMT F 40	RM F-SC 40 SMT F 40
371	MECHANICAL SEAL KIT	25	O-RING (PUMP BODY ~)	ZBR25620			1
		24	SEAL (COMPLETE				1
372	HYDRAULIC KIT	21	IMPELLER	ZBR45880	1 pcs.	ZBR45890	1
		12	DIFFUSER (WELDED ~)	1 pcs.			1
473	SELF-PRIMING SUCTION FLANGE KIT	16	16 O-RING (NOZZLE ~) 1 pc	ZBR28140			1
		84	84 PLUG (FRONT ~) 1 pc				1
		88	88 SHUTTER 1 pc				1
		490	490 RUBBER SPACER 1 pc				1
		89	89 SPRING (SHUTTER ~) 1 pc				1
		370	370 SELF-PRIMING SUCTION				1

List of spare parts for *RM Favorit* and *RM Favorit-SC*

5.4 Components of supplemental supply

The floating valve keeps the water level constant in the supplemental supply container. The maximum water level should be approx. 2-3 cm below the overflow rim when the floating valves closed (backside of the container).

The correct distance of the float (5) to the horizontal lever is factory set at 85 mm by the RMF20 valve and 90 mm by the RMF40 valve.

Note: If an overflow occurs due to continuous dripping from the valve, the valve must be decalcified (see Maintenance). In the connection of the float valve there is a protective sieve (3) which can be pulled out for cleaning. A strainer is also located in the inlet pipe.

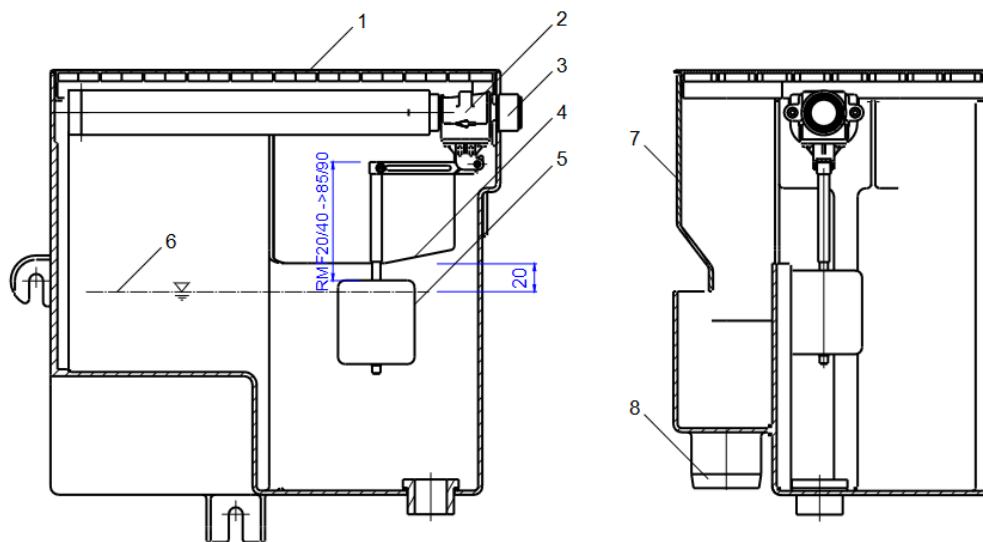

- | | |
|----------------------------------|------------------------|
| 1. Supplemental supply container | 5. Lifting body |
| 2. Floating valve | 6. Maximum water level |
| 3. Protective sieve | 7. Splash protection |
| 4. Emergency overflow rim | 8. Emergency overflow |

5.5 Components of the electronic 3/2-way ball valve

The motorised ball valve selects between rainwater intake and mains water intake. The built-in display on the valve shows which mode is currently selected.

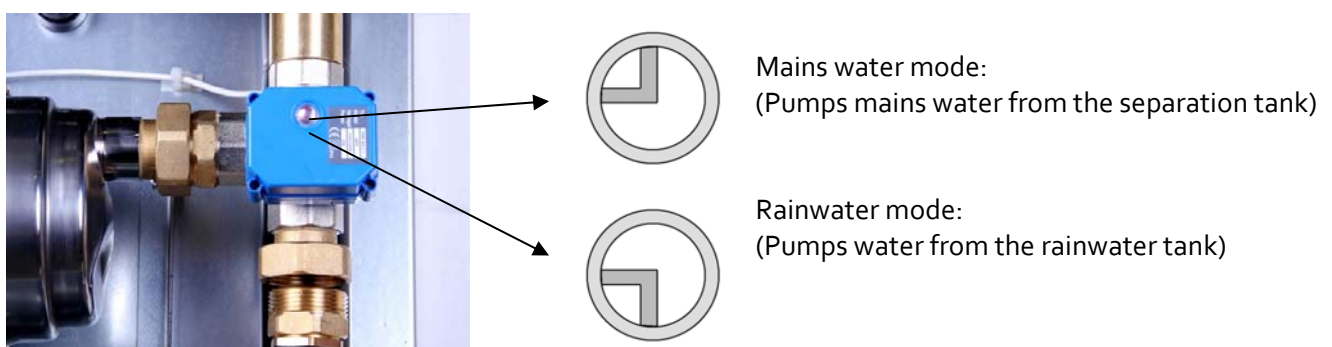

6. Installation instructions

6.1 Wall mounting

The *RM Favorit-SC* is mounted on a wall with the supplied wall bracket. The lid and lateral distances indicated should be adhered to when mounting, to provide clear maintenance access.

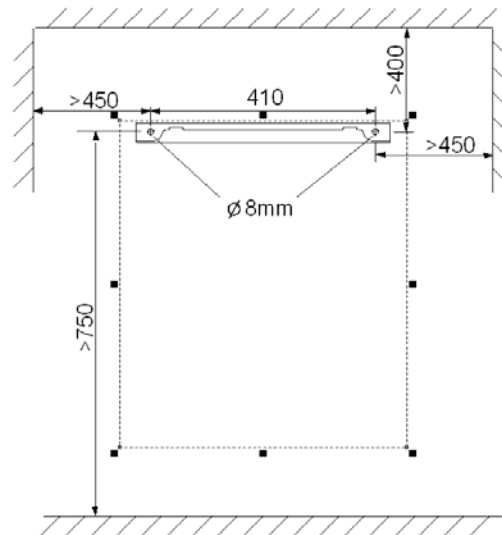

The *RM Favorit-SC* is wall mounted in such a way, that the groove in the top back panel of the unit hangs off the affixed wall bracket.



The provided rubber clamping device is to be fit on the back side of the unit in the lower corners.
Thanks to the rubber pads, the device can be installed close to the wall. The unevenness of the wall can be balanced by various screwing depths.

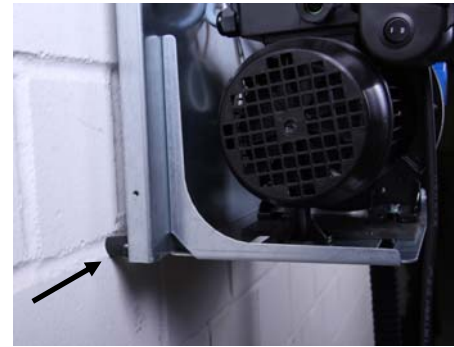

6.2 Connection to the mains water line

The connection to the mains water supply is done with the provided flexible hose and stopcock.

Screw the gland screw into the container connection and carefully tighten with a fixed wrench.

Note:

The flexible hose must not be overtightened as this may interfere with the internal float valve on the opposite side of the connection. All provided flexible hoses have gland screws with flat washers. The rubber washers must be present. Additional sealing material must not be used on gland nuts!

Screw the gland screw on the other end of the flexible pipe into the stopcock (not scope of the delivery) mounted on the mains water line.



6.3 Installations on the suction side

The installation of the intake requires special attention, since only correct mounting and sealing ensures trouble-free operation of the system. For fault-free functioning, ensure the guidelines concerning intake height and intake length are followed carefully (see Chapter 4.2.).

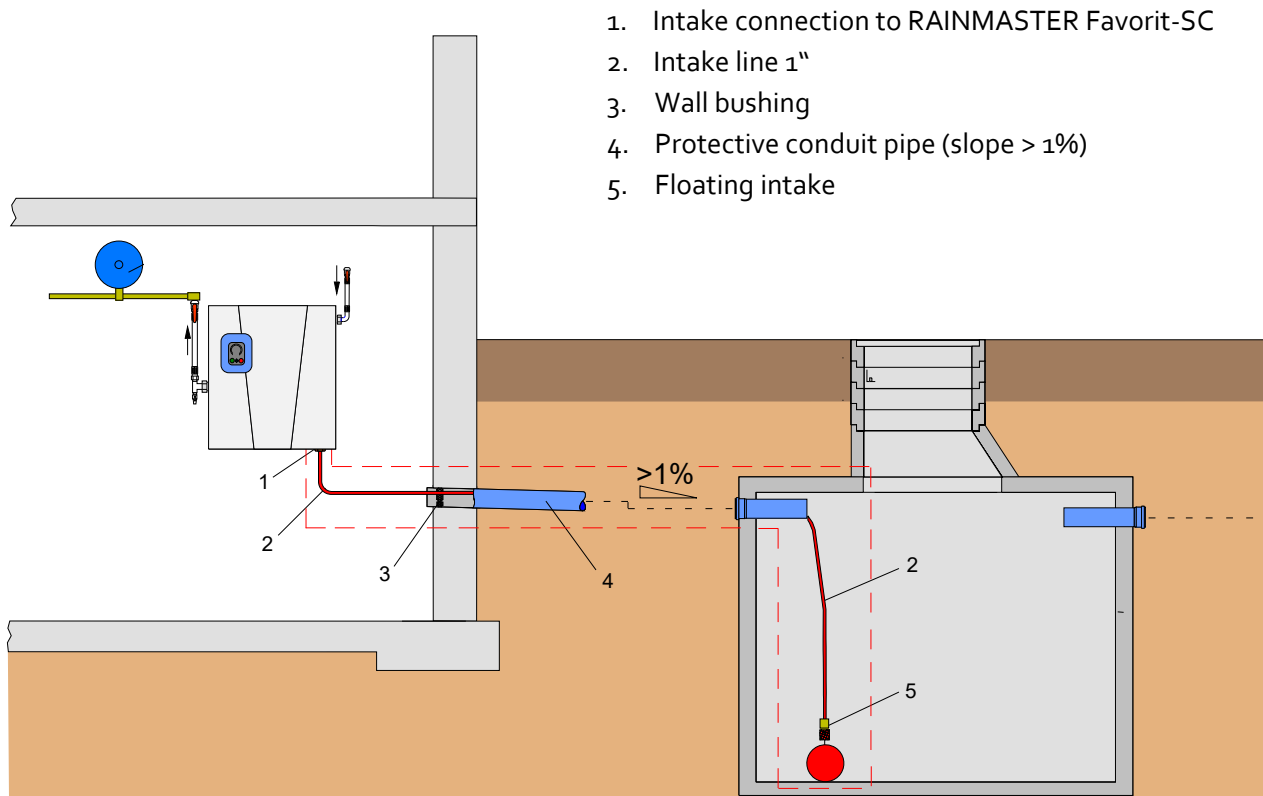

1. Intake connection to RAINMASTER Favorit-SC
2. Intake line 1"
3. Wall bushing
4. Protective conduit pipe (slope > 1%)
5. Floating intake

6.3.1 Installation of a protective conduit pipe

The intake line must be installed in a (DN100) protective conduit pipe in order to ensure all intake lines and pipes are protected from damage and can be accessed freely at any time. In order to avoid water accumulating in the conduit, it must be installed with > 1 % slope back towards the tank.

In general, all lines carried in the protective pipe should pass through a wall bushing (for example INTEWA MD100 Article number: 610050) at the house. This prevents water from outside entering the basement/garage/utility room. The wall bushing must be mounted as per instructions so that the intake line is never squeezed or kinked (narrowing of the cross section).

6.3.2 Layout of the intake line

As intake line, a flexible negative pressure resistant hose that doesn't contract under vacuum should be used. This allows you to create a floating intake in the tank. The INTEWA intake hose SDS meets these requirements.

In order to avoid potential leaks at connection points, it is strongly recommended that the intake hose (from the intake filter in the tank all the way to the RM Favorit unit) should be one piece – containing no joins.

Warning instructions:

The internal diameter of the intake hose must be at least $D=26$ mm in order to obtain full volume flow.



Water filters may not be used in the intake line, since the gaskets are not designed for underpressure operation. The underpressure for intakes cannot be made up later and air will enter the intake line.



PVC corrugated hoses are not suitable as rainwater suction lines. Experience has shown that after some time these become brittle and permeable to gas/air.



No flexible hoses can be used in the intake region since these soft, internal rubber coated hoses are constricted with underpressure.



The intake hose line must never bend, kink or be constricted in any way.



6.3.3 Intake line connection

The intake line is routed through the wall into the house, and connected to the RM Favorit-SC.

The gland screw is to be tightened to the RM Favorit-SC connector.

Since the intake hose should not exert any force on the coupling to the unit, the pipe should be securely fastened to the wall with separate pipe clamps.



6.3.4 Installation of the floating intake

For best water quality, we recommend the intake line in the tank is installed as a floating intake.

The accessory product SAUGSAGF 1" (Article No. 210130) is designed for this requirement. The rainwater is drawn from just below the water surface where the water is the cleanest. The integrated non-return valve ensures that water is always present in the suction line. The intake sieve provides additional protection against debris clogging the pump.

If the intake accessory is installed on site, make sure that the intake has a non-return valve, as well as an intake filter. The intake is mounted in such a way, that with the tank being empty, the intake sits at a minimum distance of 20 cm from the bottom of the tank. In this way, the intake of base sediment is safely prevented.

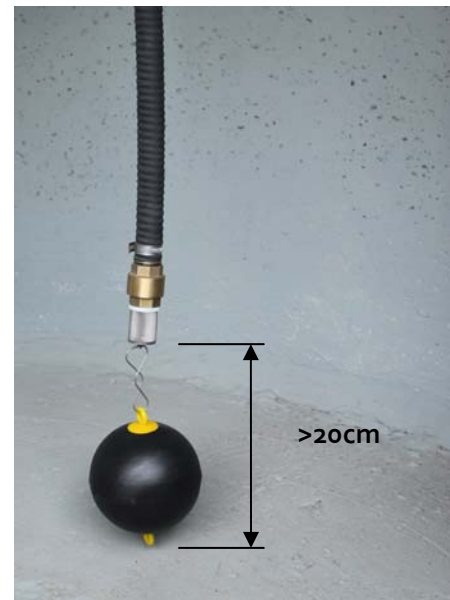

6.4 Installation of the pressure line set

The pressure line set (see scope of delivery) establishes the connection between the pump and pressure line system.

The pressure line set is connected to the pump controller.



The flexible hose and the shut-off valve then connect to the pressure line set and the pressure line.



Attention:

For smooth and efficient pressure regulation, a 5 Litre expansion vessel (4) in the pressure line is absolutely necessary. The air inlet pressure of the vessel must be 2 bar.

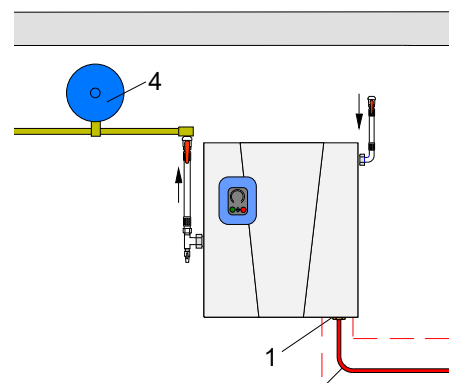

6.5 Connecting the emergency overflow

The *RM Favorit-SC* has an emergency overflow line (DN 50) which must be connected to the waste drainage system of the building. The drainage line must be of a size to accommodate a maximum volume flow rate of 90 L/min.

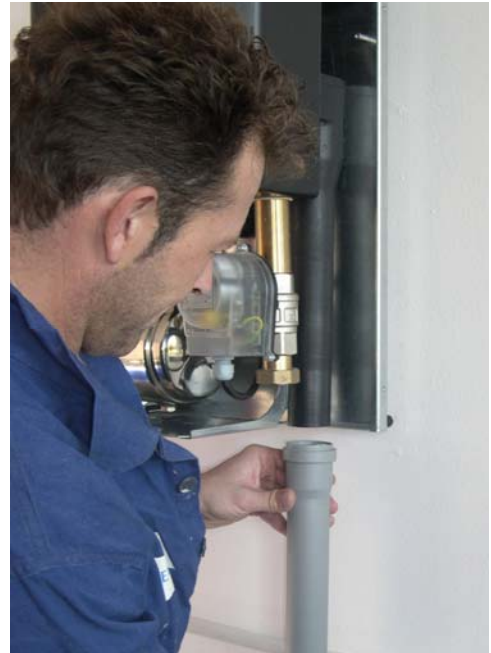

Note:

The position of the backwater level must be taken into consideration while connecting to a drainage system, in order to prevent backflow of drainage water from the open sewer line (design according to the DIN EN 1717) entering the *RM Favorit-SC*.

The position of the backwater level determines the type of line:

- a) Backwater level **above** the emergency overflow drainage height of the supplemental supply container:
 Connection to the emergency overflow must be done by a lift pump.

- b) Backwater level **below** the emergency overflow drainage height of the supplemental supply container:
 Connection of the emergency overflow to a ventilated channel line (DN 50) is done via a siphon.

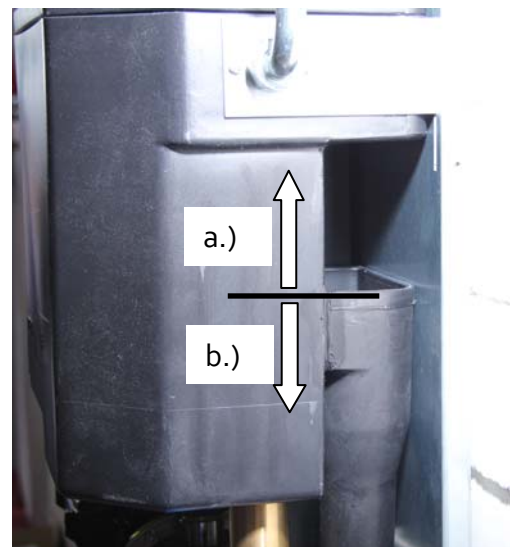

6.6 Installation and adjustment of the float switch

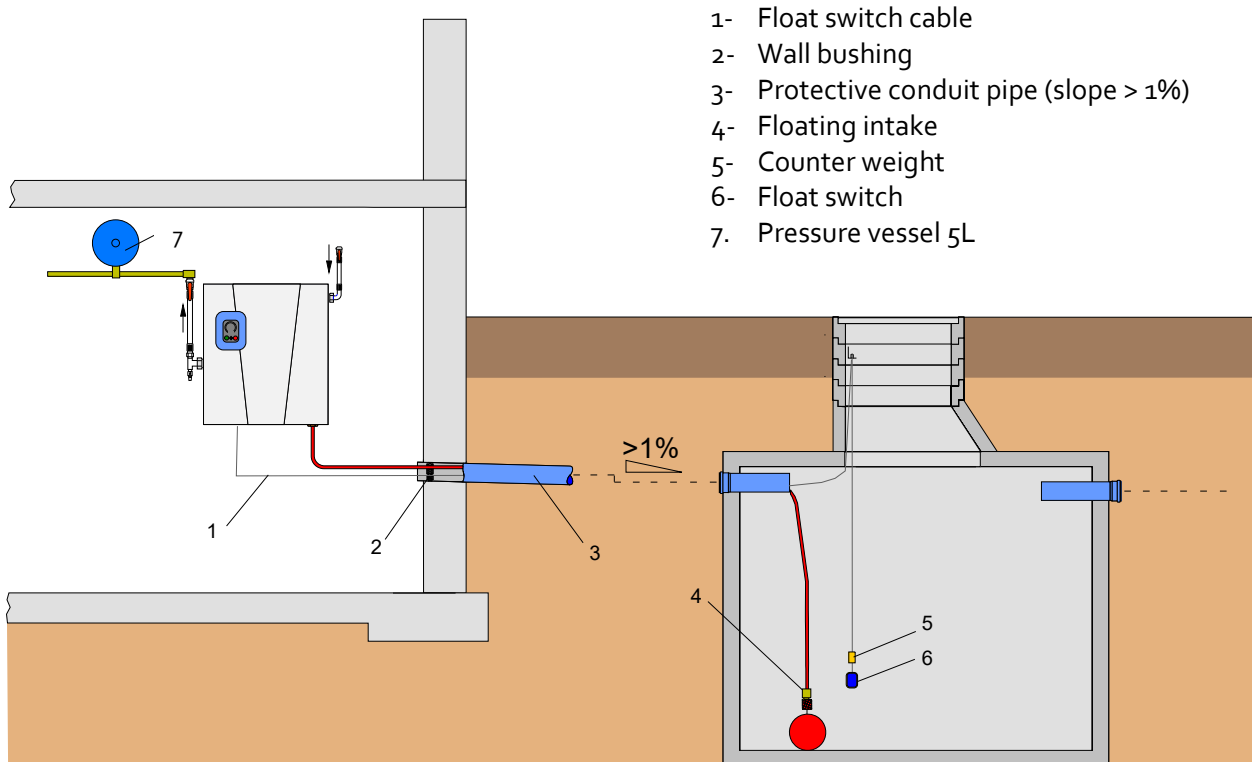

The float switch cable is housed in the same protective conduit as the intake line, for easy access and protection from damage. Therefore it is necessary to disconnect the cable from the pump terminal. Don't forget to fit the cable gland for the fixing point.

The fixing point for the float switch cable is installed in an accessible area of the tank opening so that it is possible to access (such as for inspection and maintenance purposes) even with a full tank level. The necessary height can be adjusted by means if the built-in cable gland.



The float switch counter weight (A) is mounted 15 cm above the float switch. The safety distance between the intake filter and the bottom of the float switch must be at least 10 cm (B), allowing the float switch enough cable length for free movement.

The float switch is electrically connected to the base controller (see Section 5.1).

Note:

The distance to all inner mounted parts in the cistern must be selected in such a way that the float switch can freely float.

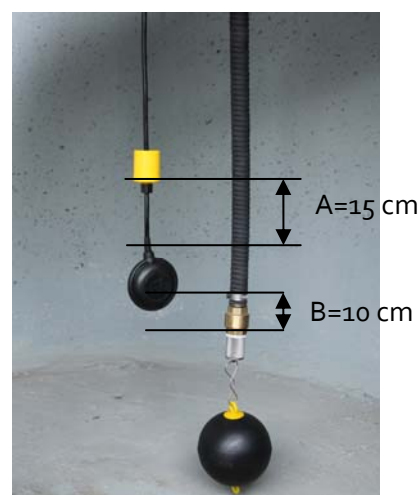

7. Start up and use

7.1 Start-up in mains water mode

1. Check that all lines are connected. Select maintenance mode = **Switch position II**.
2. Open the mains water line stopcock so that the supplemental supply container is filled with water.

Note:

In maintenance mode the pump primed with water automatically over the mains water tank. In this case the pump doesn't need to be filled up with water by hand.

Attention:

The pump must not be dry!

3. Close the pressure shut-off valve.



4. Open the air valve (hold a bucket for water under the air valve) and start the pump by plugging in the mains power. (The 3/2 ball valve switches to mains water if still in the rainwater position).

Let the water run from the air valve into the water bucket until there is no more sign of bubbles (a clear stream) meaning that all air has been removed from the suction line.



5. Close the air valve.



6. Open the pressure shut-off valve and release the air from the pressure line (e.g. by flushing the toilet several times or opening the garden tap).



7. Close all the fixtures.
The pump will now automatically switch off when the maximum system pressure is reached.

7.2 Start-up in rainwater mode

Note:

If the mains water start-up operation is not possible as described above (i.e. if mains water is not available) then the pump must be primed with approx. one litre of water before initial start-up. This is done through the filling screw at the top of the pump. Only now can the rainwater mode be started!

Alternatively, the pump can be topped up by the potable water tank as well. For this purpose, the tank is filled with about 2 L of water and the pump is started in mains water mode.



1. Select Automatic mode = **Switch position I**

Note:

The rainwater mode can be started only if there is sufficient water in the rainwater tank. This can be seen when the 3/2-way ball valve if switch position I changes to the rainwater setting (see chapter 5.4).



2. Close the pressure shut-off valve.



3. Open the air valve (hold a bucket of water under the air valve) and start the pump by plugging in the mains power. The motorised ball valve will move into the "rainwater" intake position unless water is present in the separation tank.



4. Let the water run from the air valve into the water bucket until there is no more sign of bubbles (a clear stream), meaning that all the air has been removed from the suction line.

5. Close the air valve.



6. Open the pressure shut-off valve and release the air from the pressure line (e.g. by flushing the toilet several times or opening the garden tap).

7. Close all the fixtures.

The pump will now automatically switch off when the maximum system pressure is reached.

The unit is now ready to use.

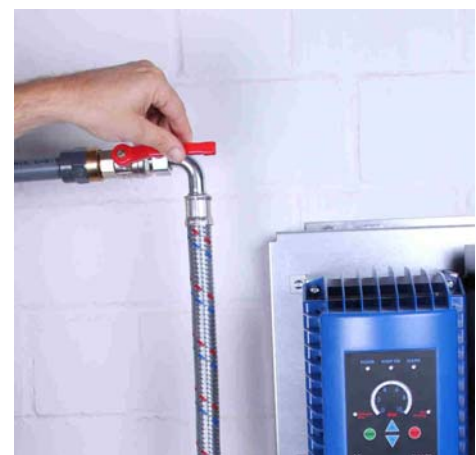

7.3 Modes of operation and display

The green LED on the pump controller indicates that the pump is ready to use. In case of a problem, the red LED will light up (see chapter 5.1)

The system pressure can be read on the pressure LED indication of the pump controller.

The Automatic Mode or Maintenance Mode can be set via the mode selecting switch.

7.3.1 Automatic mode (Switching position I)

Automatic mode is the normal operating mode, and is selected by Switch position I.

In this mode, the unit automatically switches from rainwater to mains water if the float switch detects that the rainwater tank is empty.

Two operating modes can be used according to the two positions of the float switch, both of which are indicated by the display of the motorized valve (see chapter 5.4).



- Rainwater mode:
Rainwater tank is full
(Float switch remains floating upright in the tank)

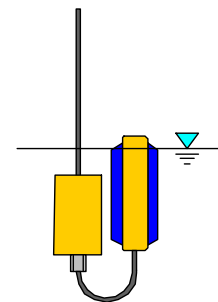

- Mains water mode:
Rainwater Tank is empty
(Float switch hangs vertically towards tank bottom)

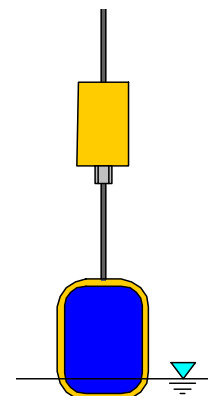

7.3.2 Maintenance mode (Switch position II)

The maintenance mode is selected by Switch position II. This mode is selected only when maintenance is to be performed in the tank. The RM Favorit-SC then operates in continuous mains water mode, independent of the float switch.



8. Safety monitoring and error notifications

N°	Alarm type with ALARM led ON	Protection	Description
A1		Current monitoring	The logic switches off the power instantaneously if this value exceeds a peak that can damage the power electronic components <ul style="list-style-type: none"> - high starting current - short-circuit on motor.
A2		Over voltage	The logic switches off the current if the voltage exceeds a maximum instantaneous limit (+15%Vn)
A3		Under voltage	If the voltage goes below the minimum value (-15%Vn) the power supply may provide an under voltage to some electronic components; for this the logic switches off the current.
A4		Temperature protection	If the temperature of the electronic components (IGBT) exceeds 85°C the inverter provides thermal protection and stops the current. This protection starts before the motor current reaches 90% of the value imposed (F2)
A5		Overload protection	The overload current is limited beyond a certain time (defined by an I ² t algorithm) to protect the insulation of the motor (<i>For the correct functioning of this protection set the nominal motor current (F2)</i>).
A6		Pressure transducer failure	In case of a problem or failure of the pressure transducer, the controller switches off the pump. Restart must be done manually, pressing and holding STOP followed by START.
A7		Flow rate monitoring	This monitoring stops the pump when all fixtures are closed and the flow of water returns to zero (normal operation).

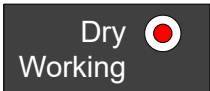
A8		Dry running	If no water is supplied, the LED blinks and the pump stops after 40 seconds. After 5 unsuccessful automatic restarts, the pump permanently stops and the LED turns solid.
----	-----------------------------------------------------------------------------------	-------------	---------------------------------------------------------------------------------------------------------------------------------------------------------------------------

All alarms are shown with the corresponding LED on the circular LED display. The alarm indicator blinks if the alarm has an automatic restart function (e.g. Dry running). The alarm does not blink, if a manual restart is necessary for safety (press STOP, the START).

Protections and alarm details:

CURRENT PICK PROTECTION (A1):

The inverter immediately stops the current in case this value exceeds a maximum limit for the electronic components.



CLOSED DELIVERY WORKING PROTECTION (A7):

To prevent pump operation with closed delivery, the control logic monitors the motor's operating point condition in comparison to the pump operating curve. If the operating point is below the pump curve, the controller switches off the pump and displays "Minimum Flow". (The pump operating curve is detected by the self-initialization check.)

DRY WORKING PROTECTION (A8):

To prevent the pump from operating in the absence of water, once a pre-programmed minimum is achieved, the "Dry Working" alarm will begin blinking. Every 15 minutes, a new automatic restart sequence will begin until a new self-initialization is achieved. After the 5th restart, the alarm LED will stop blinking and remain solid and a manual restart must be performed by the user. (Press STOP, then press START.)

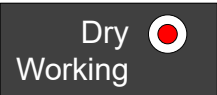
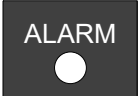
9. Troubleshooting

Description of error	Cause	Solution
Pump does not start: "Dry Working" illuminated "ALARM" not illuminated  	Dry running protection has been activated. An automatic restart will begin inside of the next 15 min. After the fifth unsuccessful restart, the unit goes into alarm mode.	Wait or Manually interrupt the restart sequence by pressing STOP. Start the pump again by pressing START.
Pump does not start: "Dry Working" illuminated and "ALARM" illuminated 	a.) Air in intake line, as float switch has not registered an empty tank and did not switch to mains water mode b.) Air in intake line because of leak	a.) Check the functioning and position of the float switch (see chapter 6.6), afterwards perform new start up (see chapter 7) b.) Seal connection points and the intake line. Afterwards perform new start up (see chapter 7)



c.) Non-return valve in intake line has a leak

c.) Change non-return valve

Description of error	Cause	Solution
Pump runs for long periods at a low velocity or turns on without fixtures being opened	<ul style="list-style-type: none"> a.) Unsealed, leaky fixtures b.) Minimal water flow at fixture (< 1 L/min) c.) Selected operating pressure too high d.) Settings changed or faulty 	<ul style="list-style-type: none"> a.) Repair leakage b.) Check fixtures c.) Minimise operating pressure (optimally 3 bar) d.) RESET and perform new self-initialization
In rainwater mode: Flow rate is too low or pump does not supply any water	<ul style="list-style-type: none"> a.) Intake filter is clogged b.) Intake hose is kinked c.) Suction line or the connections are not sealed d.) No switchover to mains water since float switch is incorrectly positioned or is defective 	<ul style="list-style-type: none"> a) clean intake filter b.) check intake line c.) check intake line and connections d.) check the functioning and position of the float switch (see chapter 6.3.4), then restart
In mains water mode: Flow rate is too low or the pump does not supply any water	<ul style="list-style-type: none"> a.) Not enough or no water present in the separation tank b.) 3/2-way ball valve does not switch over to mains water mode 	<ul style="list-style-type: none"> a.) a.) check pressure of mains water, clean filter sieve in inlet backup valve (see chapter 5.3) b.) b.) Change 3/2-way ball valve
System does not automatically switch from rainwater to mains water and vice versa.	<ul style="list-style-type: none"> a.) Float switch is not correctly positioned b.) Float switch is defective c.) 3/2-way ball valve does not switch over in spite of the float switch signal 	<ul style="list-style-type: none"> a.) Check the functioning and position of the float switch (see Chapter 6.3.4), then restart b.) Change float switch c.) Change 3/2-way ball valve
Pump pressure achieves only half the maximum pressure	<ul style="list-style-type: none"> a.) Defective air separator or impeller 	<ul style="list-style-type: none"> a.) Replace air separator or impeller

10. Maintenance

Every 3 months a visual and operations test must be completed.

If the mains water valve continuously drips, then this must be decalcified. Therefore, remove the entire valve from the tank and place it in a decalcifying solution (citric acid) so that the inlet and outlet are fully submerged. Move the floating arm several times so that the decalcifying solution penetrates the valve diaphragm chamber as well (24 hours exposure time). If the dripping continues after maintenance, then the valve must be replaced.

Every six months, the floating suction filter in the rainwater tank should be checked and cleaned. At least once a year the correct pre-pressure of 2 bar on the expansion vessel must be checked.

11. Spare parts

Description	Position No. (see chapter 4.1)	Part name
Multistage centrifugal pump RM-F20-SC	[1]	RMF-SC-P20
Multistage centrifugal pump RM-F40-SC	[1]	RMF-SC-P30
Basic controller	[2]	RMF-SC-BPL
Pump controller SC incl. pressure transducer	[5]	RMF-SC-PST
Pressure transducer 4-20 mA	[6]	RMF-SC-DS
Separation tank	[7]	RMF-B
Floating valve for separation tank	[9]	RMF-NSP
3/2-way ball valve	[10]	RMF-KH
Floating switch, 15m	Not shown	RMF-SCHW15
Spare parts for centrifugal pump		see Chapter 5.3

12. Optional Accessories

RAINMASTER D-24, Art. No. 220092

The RAINMASTER D 24 is a fill level display unit for water tanks up to 3 m depth. It can be installed everywhere in the house and is a perfect complement for the RAINMASTER Favorit SC rainwater unit.



13. Guarantee

INTEWA GmbH guarantees this unit for 24 months from the date of purchase. Kindly keep the sales receipt as proof of purchase.

Within the guarantee period, INTEWA GmbH reserves the right to either repair or replace faulty parts at its own discretion.

The warranty does not cover any damage due to improper use, wear and tear, or intervention by third parties. The warranty does not cover any defects which may only minutely affect the value or usability of the device.

14. Contact / Unit serial number

For customers in Germany:

For any queries, ordering of spare parts, as well as in case of service, kindly contact INTEWA GmbH directly, quoting your product's model and identification numbers and the purchase invoice details, at:

INTEWA GmbH
Auf der HÜls 182
52068 Aachen

Tel.: 0049-241-96605-0
Fax: 0049-241-96605-10
Email: info@intewa.de
Internet: www.intewa.de

For customers in other countries:

For any queries, ordering of spare parts, as well as in case of service, kindly contact your installer or the authorised importer, quoting your product's model and identification numbers, and the purchase invoice details.

Your RAINMASTER Favorit SC identification number is displayed on the right hand top side of the mains water tank. The unit housing must be removed to see this.

Annex 1.0 Scope of duplex or triplex application

For larger commercial applications, where pumping reliability and consistency is a must, the speed-controlled *RM Favorit SC* models are used to ensure water is always efficiently and reliably delivered to the required application. Up to three *RM Favorit SC* units can be connected in parallel, as a powerful multiple pumping system.

The units communicate together via Bluetooth. In this configuration, should one pump ever fail, the others simply take on the load. Through Bluetooth the automatic, bidirectional start-up of the pumps, the peak load connection and the operating pressure settings are aligned and transferred wirelessly.

Slave and Master functions are automatically transferred to the operating units in the event of an equipment malfunction.

Annex 1.1 Intake variants

When using duplex or triplex *RM Favorit SC* units in parallel, you have the option of a central 1 ½" intake INTEWA SAGF 1 ½" from the tank or to connect to any single device with a 1" intake (INTEWA SAGF 1".) If the intake line is longer, and/or the intake height higher, than the recommended pump specifications, then a hybrid container must be used in order to increase the parameters of the pumping system. The hybrid container supplied from the main tank by the charging pump.

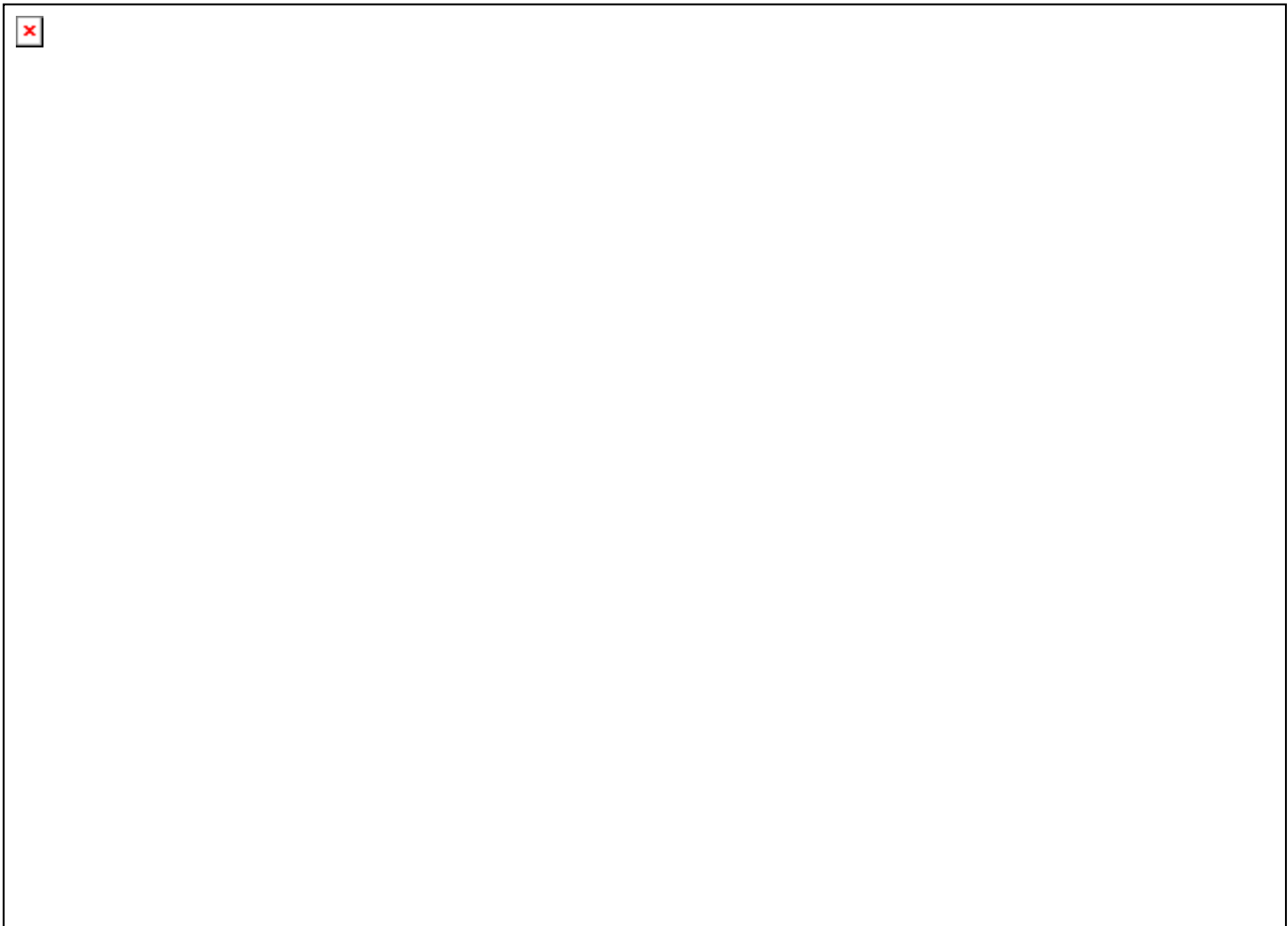

Sample overview of a rainwater harvesting system using three (triplex) *RM Favorit SC* units connected in parallel.

Legend:

- | | |
|----------------------------------------------------|---------------------------------------------------------------|
| 1: RAINMASTER Favorit Rainwater system | 10: Emergency overflow hybrid tank |
| 2: Mains water connection | 11: Float switch mains water |
| 3: Pressure line set | 12: Float switch charging pump |
| 4: Expansion tank | 13: Protective conduit for intake line and sensor cable |
| 5: Pressure line to consumers | 14: Rainwater inlet pipe |
| 6: Cable of float switch for switch to mains water | 15: PURAIN Rainwater filter |
| 7: Central intake lin with SAGF 1 1/2" | 16: Charging pump |
| 8: Emergency overflow | 17: Float switch protection against dry running charging pump |
| 9: RMF-SC Hybrid | |

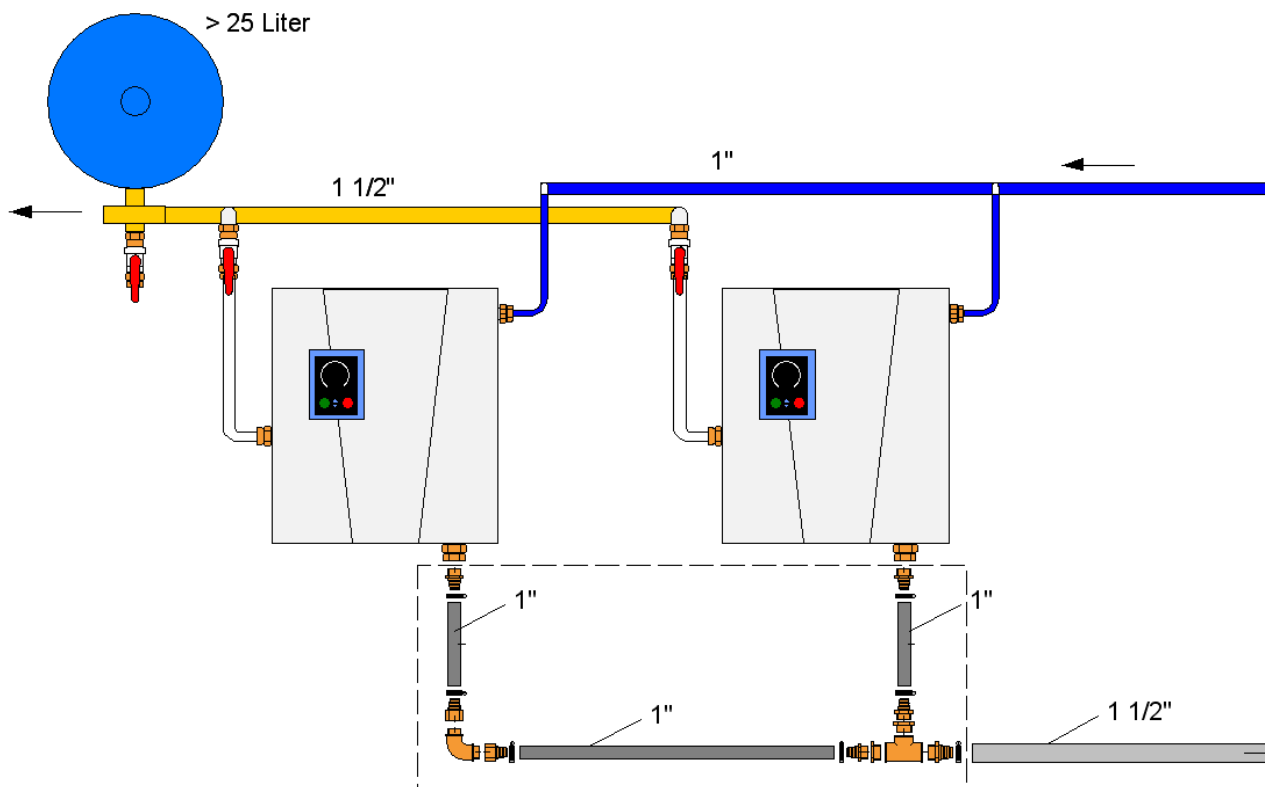

Picture connection fittings intake filter SaugSAGF 1 1/2 inch



Attention:

In the main storage or in the hybrid storage tank the floating switches for the mains water are installed. The float switch must not be connected in parallel. Each device must be connected via its own float switch!

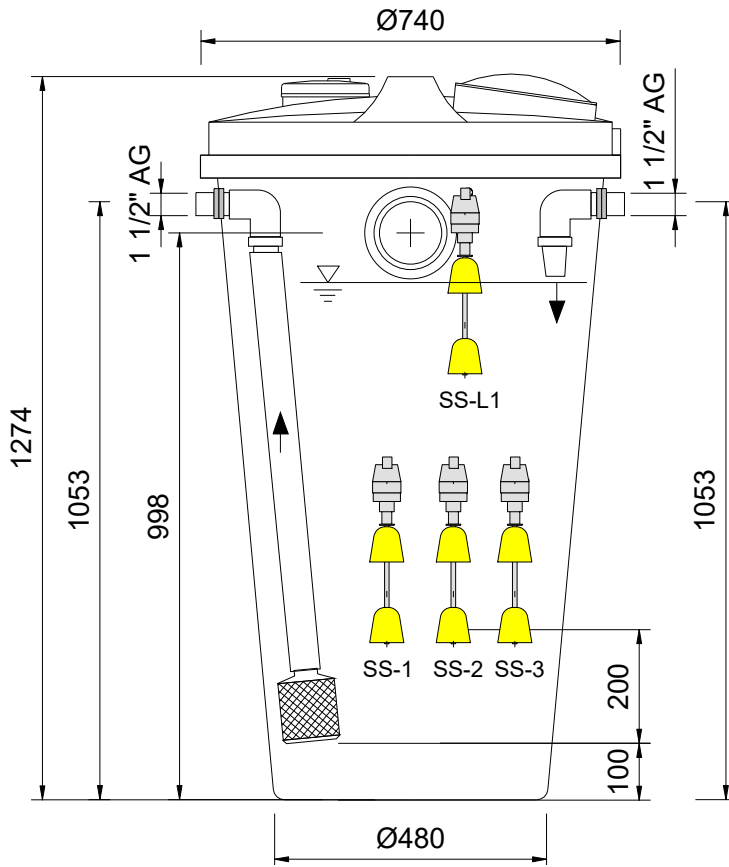
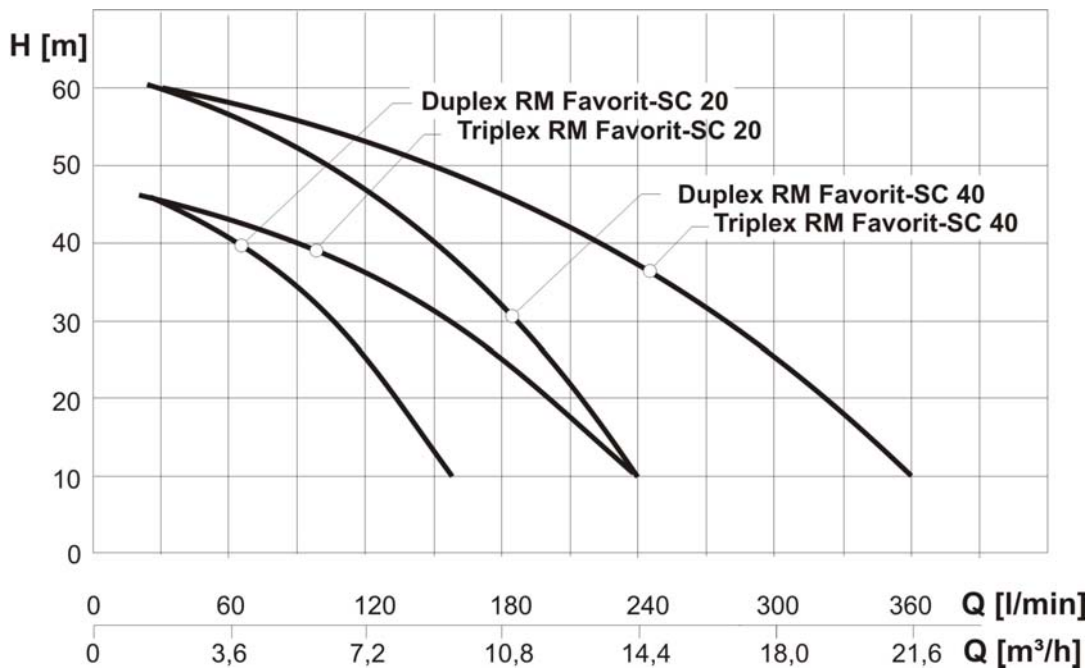

Fig. : Example of hybrid tank for a triplex plant with vertical float switch for each RMF-SC with SS-1, SS-2, SS-3 and float switch for the charge pump SS-L1

Annex 1.2 Technical data for duplex- and triplex-application

All pipes must be sized according to the maximum flow rate.



Performance curve of RMF-SC Duplex- und RMF-SC Triplex

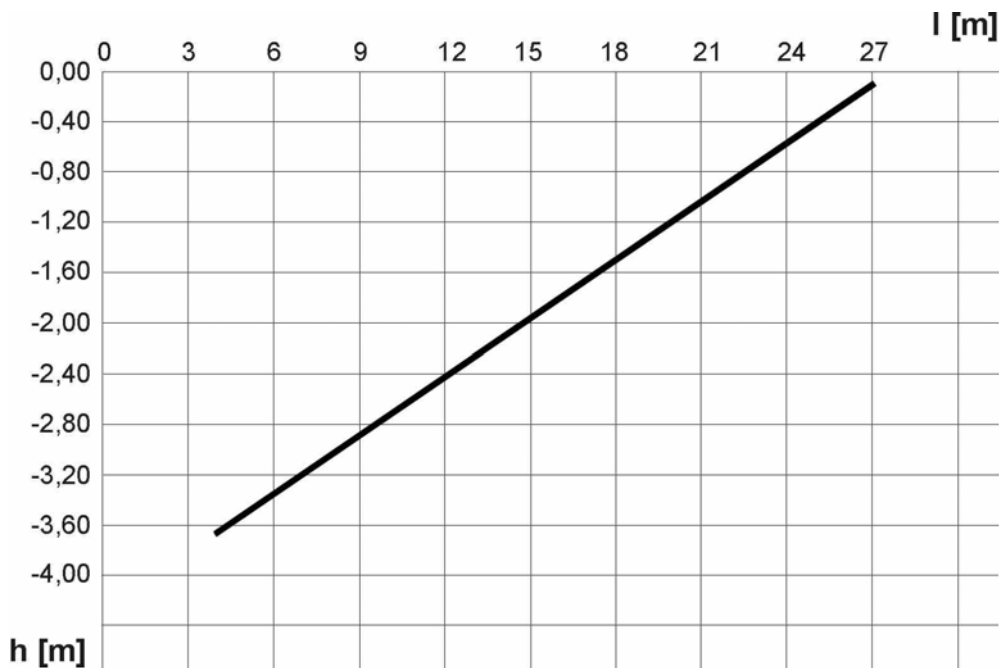



Performance curve of the intake of RMF-SC Duplex- und Triplex with 1 1/2" intake line

We suggest following sizing of a central pipe system:

	Pressure line	Mains water line	Intake line
Duplex RM Favorit-SC 20/40 Triplex RM Favorit-SC 20/40	1 1/2"	1"	1 1/2"

Annex 1.3 Group function via Bluetooth by duplex and triplex applications

1. Each RM Favorit SC unit is factory initialized, allowing pre-set operation procedures to occur. Is it still necessary to perform a self-initialization. (E.g. after a RESET), than every device has to be initialized individually.
2. In order to initiate a Bluetooth connection, the mains plug of all RMF-SC's must be inserted within 10 seconds of each other (all LEDs must be extinguished beforehand).
All Power LED's flash simultaneously when the connection with all units is obtained. This procedure lasts for approx. 20 seconds.
3. The systems are now ready to use. The pump will automatically start as soon as a decrease in pressure is detected.
4. The desired operating pressure can be adjusted by pressing  or  on any one pump controller. (The Bluetooth connection automatically transfers these settings to the other devices).

Note:

It is necessary for the *RMF-SC* to execute a fresh automatic initialization after every RESET (see Chapter 5.1.3). It is important that the other parallel connected *RMF-SC*'s remain plugged in with Power ON, in order that all units initialize successfully together via Bluetooth.

If there are several devices in the room that operate independent of each other, then the transfer frequency can be modified (see Setting F20, Chapter 5.1.4). If a pump alone runs for 30 seconds, then the pump control is determined to be "single mode" (F17-3). The Group function can then be setup, in which F17 is modified.

Annex 1.4 Parameter adjustment F17

For applications with 2 or 3 pumps in Bluetooth-operation, parameter F17 must be adjusted accordingly (see section 5.1.4).